

SmartCare Plus Electric Shower

INSTRUCTIONS

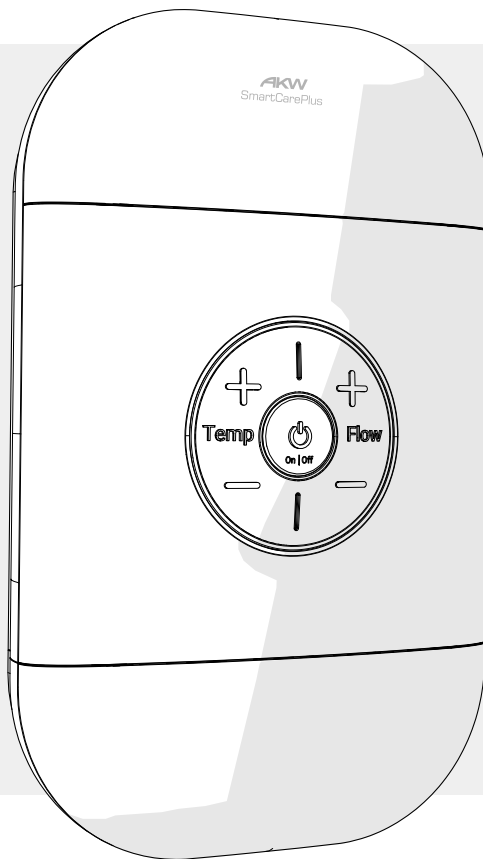

8.5 kW
30300

9.5 kW
30301

10.5 kW
30302

Please read all instructions before installation and leave this document with the end user for future reference as it contains important warranty information

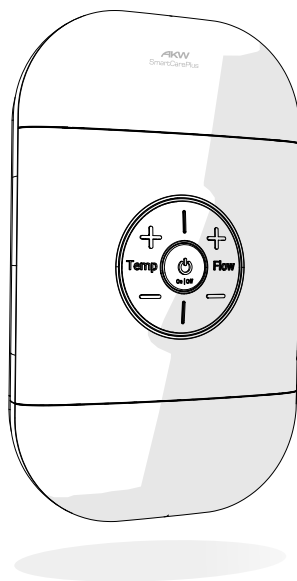

Eco Setting - Optionally select 6 litres per minute maximum flow

Automatic Shut Down - The shower automatically reverts to standby - preset time can be set at 5, 10, 20 or 30 minutes

Phased Shut Down - Flushes the shower with cold water to avoid the possibility of scalding if the shower is restarted within a short period of time

Flexible Installation

6 water and cable entry points

Dual power blocks for left or right wiring

Retro-fit footprint

8.5, 9.5 or 10.5 kW options available

Wired and wireless connectivity to all AKW DigiPump shower waste pumps

- User 4-9**
 - Safety Information 4
 - Operating Instructions 5
 - Shower Settings 6-7
 - Troubleshooting 8
 - Filter Cleaning..... 9

- Installer..... 10-17**
 - Main Components 10
 - Specifications 11
 - Installation Requirements 12
 - Disassembly 13
 - Fitting to wall - Without Fitting Plate 14
 - Fitting to wall - With Fitting Plate 15
 - Reassembly - Bottom Cover 16
 - Reassembly - Front Cover 17

- Plumbing 18-19**

- Electrical 20-21**

- Connecting Waste Pump 22**

- Commissioning 23-26**
 - Temperature & Mode Settings 23
 - Functional Checks 24
 - Commissioning 25
 - In-Service Tests 26

Safety Information

Failure to install this AKW product in accordance with supplied instructions or the making of unauthorised modifications will invalidate any warranty and may affect product safety.

AKW does not accept any liability in connection with this information or its use. This information is provided on the condition that the person receiving it shall make their own tests to determine the suitability for their particular purpose. None of the foregoing affects your statutory rights.

This appliance can be used by any persons with reduced physical, sensory or mental capabilities or lack of experience and knowledge of showering, if they have been given supervision or instruction concerning the use of the appliance in a safe way and understand the hazards involved. Children shall not play with the appliance. Cleaning and user maintenance shall not be made by children without supervision.

Do not operate shower if you suspect the water in the heater tank is frozen or the appliance has been susceptible to freezing conditions.

Do not operate the shower if the spray handset or hose is damaged or blocked.

Cleaning Recommendations

Always isolate power supply before cleaning.
Clean and descale the shower head regularly.

The shower unit and surrounding areas should be cleaned periodically to remove any accumulation of dirt or other waste materials, using domestic bathroom and kitchen cleaning materials with a soft cloth.

Do not use abrasive pads or cloths. Do not use strong or concentrated acidic, alkaline or other cleaning materials as these may damage or discolour the product.

After cleaning always wash down with water then wipe thoroughly with a damp soft cloth to remove any cleaning material residue.

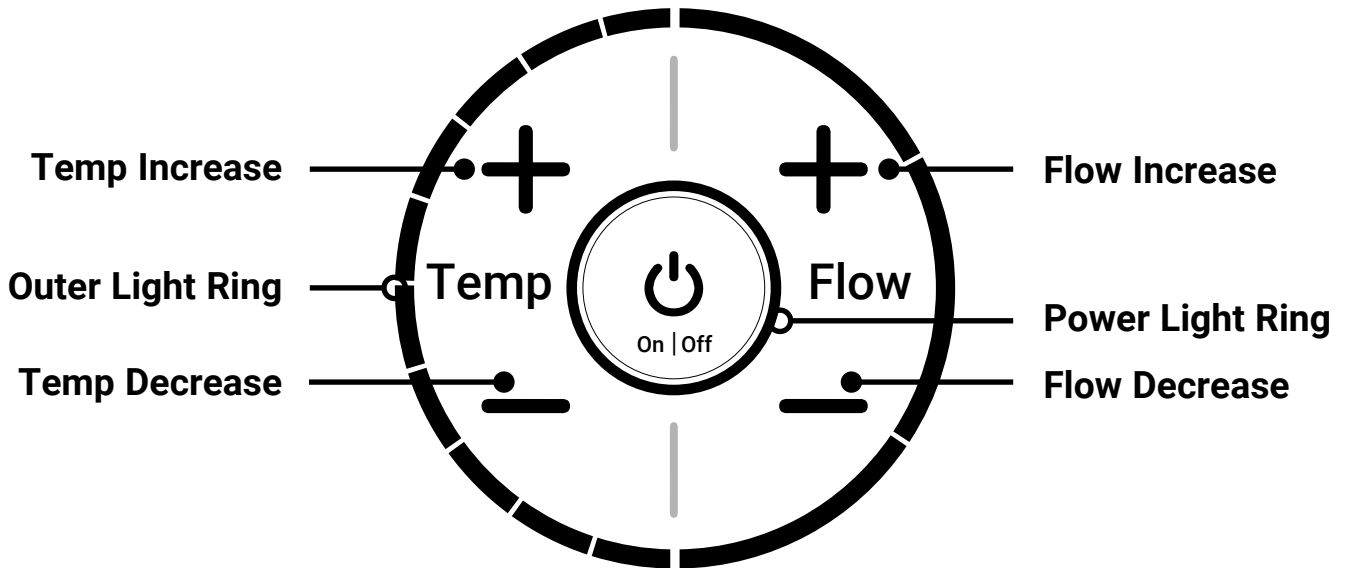

Starting the Shower

Switch on the mains power at the isolating switch.

When power is applied, the power light ring will be dimly lit and the shower is in standby mode.

To switch on, press the power button. The power light ring will be brightly lit.

Shower Settings

RNIB Mode

When running, select desired settings. **To turn RNIB on** press and hold power button for 10 seconds until you hear 3 beeps (last one should be high pitched). This ensures the shower will always turn on at the pre-defined settings. **To turn RNIB off** press and hold power button for 10 seconds until you hear 3 beeps (last one should be low pitched). When RNIB is off, the shower will always turn on using the lastly used settings.

Settings Mode

When in standby state, if the power button is pressed and held for > 5 seconds, then released, the shower enters settings mode (beep and bright power light ring).

Select the mode required by adjusting the temperature control.

If the temperature control is not adjusted within 5 seconds of releasing the power button then the shower will revert to standby state.

If the temperature control is adjusted within 5 seconds, the LEDs will illuminate proportionately (LEDs are initially blank entering settings mode).

The LEDs will remain lit for 5 seconds after last adjustment.

If while the LEDs are illuminated the power button is pressed and released, a corresponding mode will be entered as detailed below (beep/flash to confirm).

The LED order referred to below is numbered clockwise on the temperature display.

Cold Flush: this setting will be selected when only LED #1 is lit.

Volume Setting: this setting will be selected when LEDs #1 & 2 are lit.

Wireless Pump Pairing: this setting will be selected when LEDs #1, 2 & 3 are lit.

Bluetooth Pairing: this setting will be selected when LEDs #1, 2, 3 & 4 are lit.

Eco Setting: this setting will be selected when LEDs #1, 2, 3, 4 & 5 are lit.

Cold Flush

Press / release power button: cold flush starts immediately.
Press / release power button: cold flush cancelled: revert to standby state.
Cold flush will continue for 60 seconds if not cancelled as above.

Volume Setting

Press / release power button: volume set mode entered.
Select volume setting by adjusting temperature control: 1 led = no sound / 2 led = low volume / 3 led = high volume.
If temperature control is not adjusted within 5 seconds of releasing power button: revert to standby state.
Press / release power button: volume setting stored: revert to standby state.

Wireless Pump Pairing

Press / release power button: wireless pump pairing mode entered.
While in pairing mode, all LEDs off except power button led alternating between off and dim (1 second on, 1 second off).
Successful pairing (double flash / beep to confirm): revert to standby state.
Unsuccessful pairing: revert to standby state.
Press / release power button: cancel pairing: revert to standby mode
Shower will remain in pairing mode for 60 seconds unless either successfully paired or cancelled as above.

Bluetooth Pairing

Press / release power button: bluetooth pairing mode entered.
While in pairing mode, all LEDs off except power button led alternating between off and dim (1 second on, 1 second off).
Successful / unsuccessful pairing is indicated on smart device (e.g remote control, phone, tablet etc.)
Unsuccessful pairing: revert to standby state.
Press / release power button: cancel pairing: revert to standby mode
Shower will remain in pairing mode for 60 seconds unless either cancelled as above or cancelled by a command from a successfully paired device.

Eco Setting

Press / release power button: Eco setting mode is entered.
Select Eco On/Off by adjusting temperature control: 1 led = Eco Off / 2 led = Eco On
Eco On = flow limited to 6 lpm.
If temperature control is not adjusted within 5 seconds of releasing power button: revert to standby state.
Press / release power button: Eco setting stored: revert to standby state.

Note: Eco setting cannot be set to 'On' if BEAB Care mode is selected.

Troubleshooting

Read and understand the user guide before commencing troubleshooting.

Fault	Indication	Symptoms
Low pressure	POWER BUTTON led : dim TEMP leds : #1 only FLOW leds : none	Flow rate less than ~1.0 lpm Possible causes include low water pressure, starvation of supply or blockage in the inlet filter or outlet hose/handset.
Inlet thermistor	POWER BUTTON led : dim TEMP leds : #1+2 FLOW leds : none	Faulty inlet thermistor. Shower continues to run, but heating elements are disabled.
Outlet thermistor	POWER BUTTON led : dim TEMP leds : #1+2+3 FLOW leds : none	Faulty outlet thermistor. Shower continues to run, but with heating elements disabled.
Wireless pump	POWER BUTTON led : dim TEMP leds : #1+2+3+4 FLOW leds : none	Wireless signal lost for >10 seconds while shower running. (Wireless link not active while shower in standby).
Instantaneous Overtemperature	POWER BUTTON led : Dim TEMP leds : #1+2+3+4+5 FLOW leds : None	The shower continues to operate, but the heating element is turned off and the water outlet is turned off. An error prompt is displayed when the shower is running. Automatic reset when overtemperature conditions are cleared (natural cooling or rinsing cold water through shower heater).
Uncontrolled Overtemperature	POWER BUTTON led : dim TEMP leds : #all FLOW leds : none	Outlet temperature has risen uncontrollably. Possible causes include component failure or sudden starvation of water supply.

Note: all errors flash rate 1 sec on / 1 sec off

In the event that the shower fails to respond to any push-button or exhibits unusual performance characteristics during operation, turn off the electrical supply by operating the pull-cord switch or isolating switch. Wait for a few seconds for the shower to reset, then turn the power back on and press the on/off button. If the problem persists, note which fault LED is lit or flashing and contact AKW Technical Enquiries (01905 560 219 | tech@akw-ltd.co.uk).

Cleaning the Filter

This should be done only if you suspect reduced flow rate or water hardness build up.

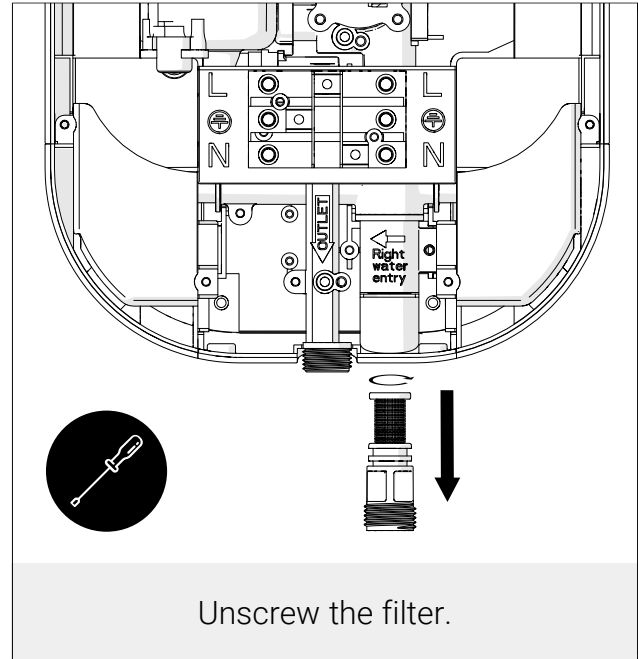
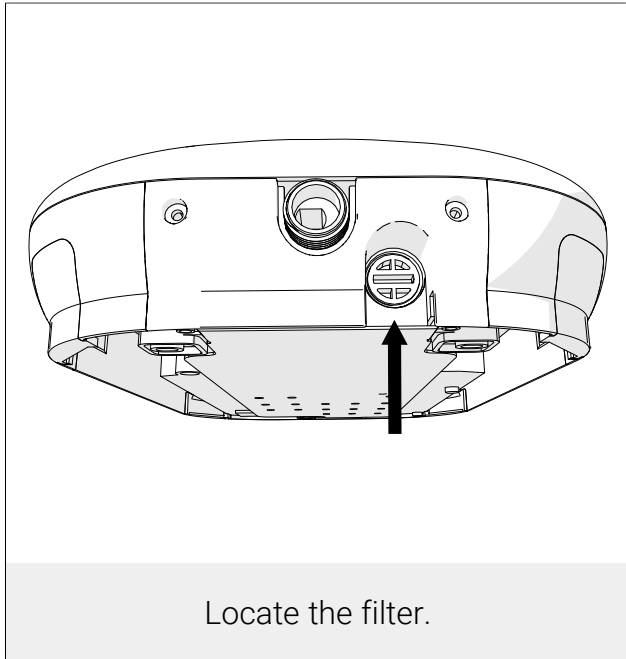

Ensure that the electrical supply is switched off at the mains.

Ensure that the water supply is turned off.

Using a flat head screwdriver, unscrew the filter.

Rinse the filter in water and once this is clean then return to the inlet housing.

Main Components

MAIN COMPONENTS

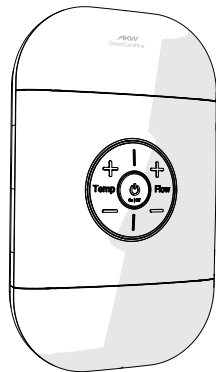
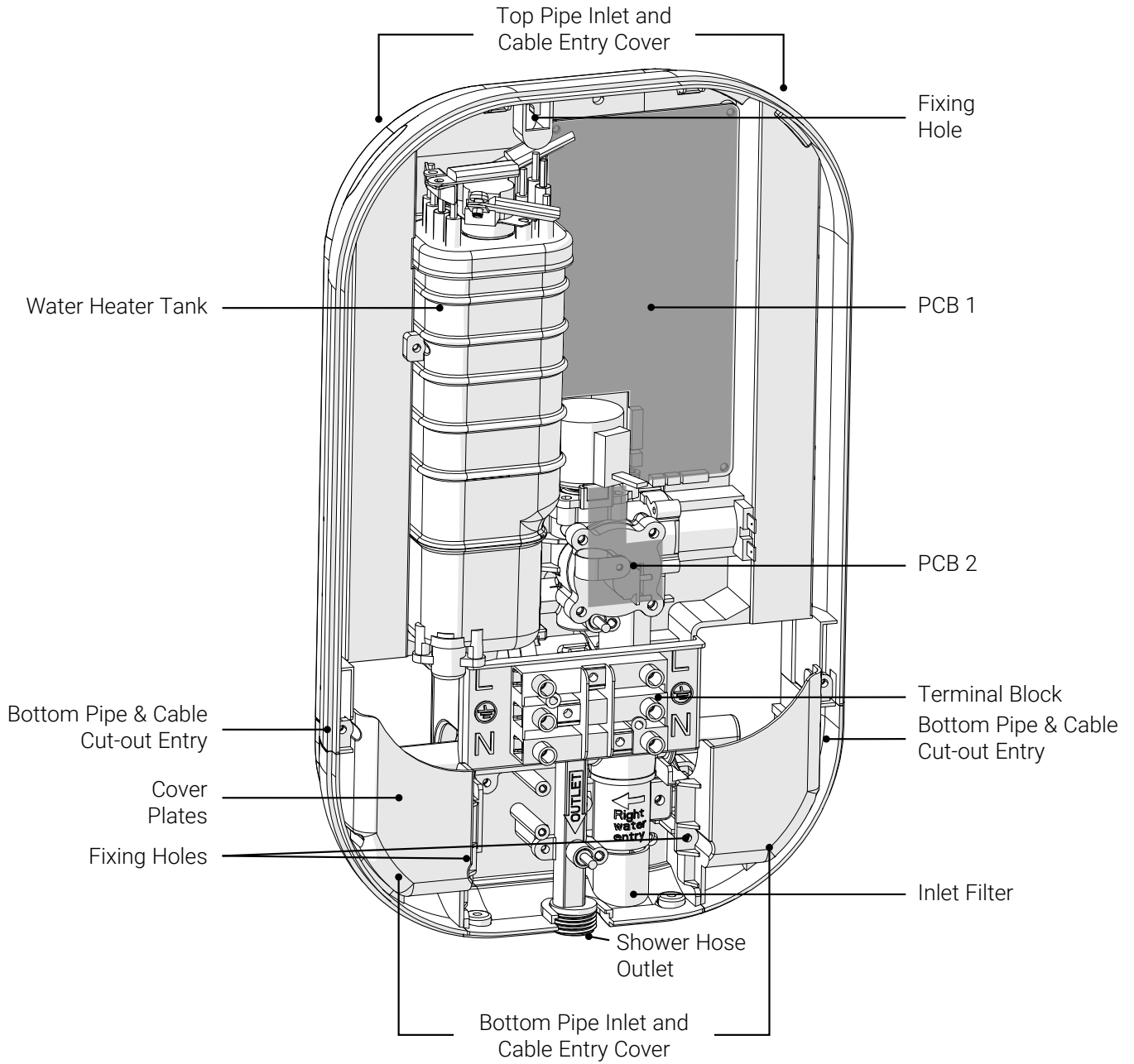

Shower Front Cover

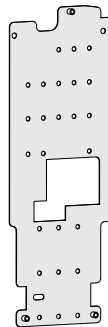

Fitting Plate

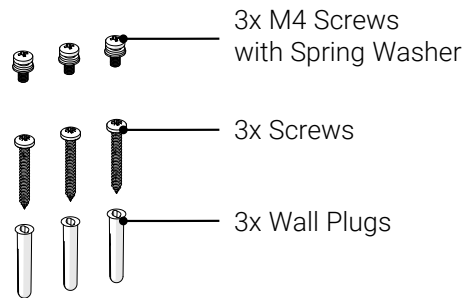

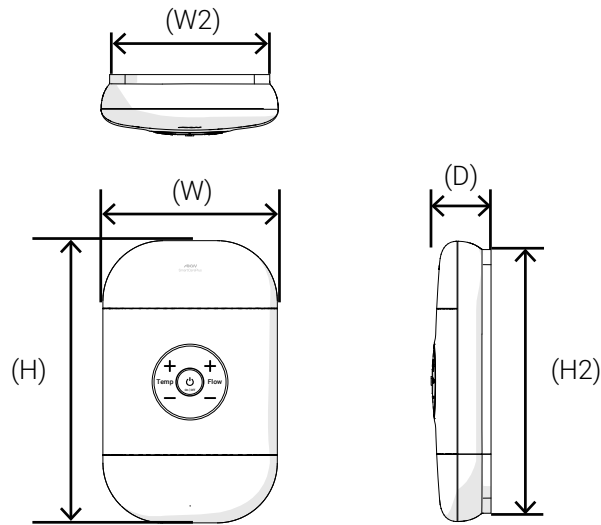

PLUMBING SUPPLY	Supply Source	Mains pressure cold water only
	Minimum Dynamic Pressure	50 kPa (0.5 Bar) (1 Bar BEAB Care)
ELECTRICITY SUPPLY	Recommended Minimum Dynamic Pressure	100 kPa (1 Bar)
	Maximum Static Pressure	1000 kPa (10 Bar)
	Maximum Inlet Temperature	28°C (20°C BEAB Care)
	Minimum Inlet Temperature	3°C (5°C BEAB Care)
	Inlet Connection	15 mm pipe
	Outlet Connection	1/2" BSP Male Thread Fitting
	Nominal Rating at 240 V	10.5 kW, 9.5 kW & 8.5 kW
	Supply Fuse / Circuit Breaker	(10.5 kW 45/50 A), (9.5 kW 40/45 A) & (8.5 kW 35/40 A)
Residual Current Device (RCD)	30 mA (must be fitted)	
PHYSICAL	Supply Cable	Refer to current wiring regulations and BS 7671 to determine minimum cable size. No larger than 10 mm ²
	Isolation Switch (e.g. Pull Cord)	50 Amp Double Pole with 3 mm contact separation.
	Height	(H) 388 mm
	Width	(W) 240 mm
	Depth	(D) 82 mm
	Footprint Height	(H2) 365 mm
Footprint Width	(W2) 218 mm	
Water Ingress Rating	IPX4	
Water and Cable Entry Points	Top, bottom or back.	

ACCREDITATIONS & CERTIFICATIONS



Installation Requirements

Installation Requirements and positioning

The shower must be connected only to the mains cold water supply.

DO

- Mount on a finished flat, waterproof surface.
- Position the shower unit vertically.
- Ensure that the shower unit is positioned over a bath, shower tray, or wet floor.
- Direct the shower head away from the shower unit. During normal use the shower head must not spray directly on to the shower unit.

DON'T

- Block, restrict or connect the water outlet pipe to any parts other than those AKW specifically state for use with the shower, as it acts as a vent.
- Position the shower where it will be subjected to freezing conditions.
- Tile up to the shower unit.
- Seal the shower to the wall with silicone or other sealant.

Before you start work:

Check that there are no pipes or electrical cables inside the wall before drilling. Check for cracks or loose tiles or grout. Make sure that all surfaces are clean, dry and free from loose debris or dust.

This product is not suitable for mounting into steam rooms or steam cubicles.

Note - If it is intended to operate the shower in areas of hard water (above 200 ppm temporary hardness), a scale inhibitor may have to be fitted.



Ensure that the electrical supply is switched off at the mains.
Ensure that the water supply is turned off.

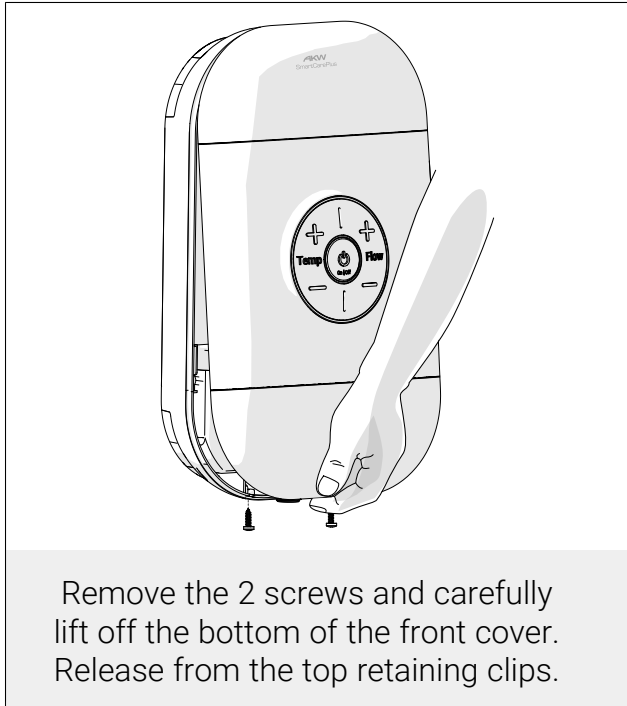

Remove the 2 screws and carefully lift off the bottom of the front cover. Release from the top retaining clips.

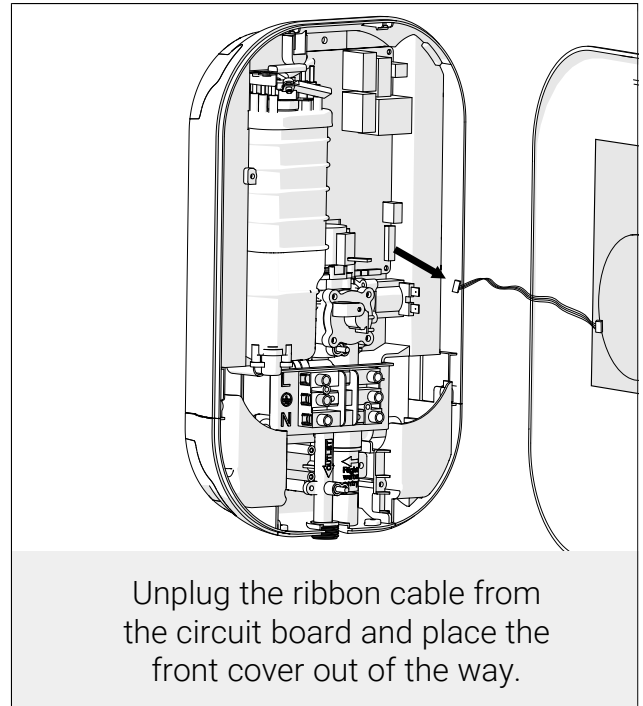

Unplug the ribbon cable from the circuit board and place the front cover out of the way.

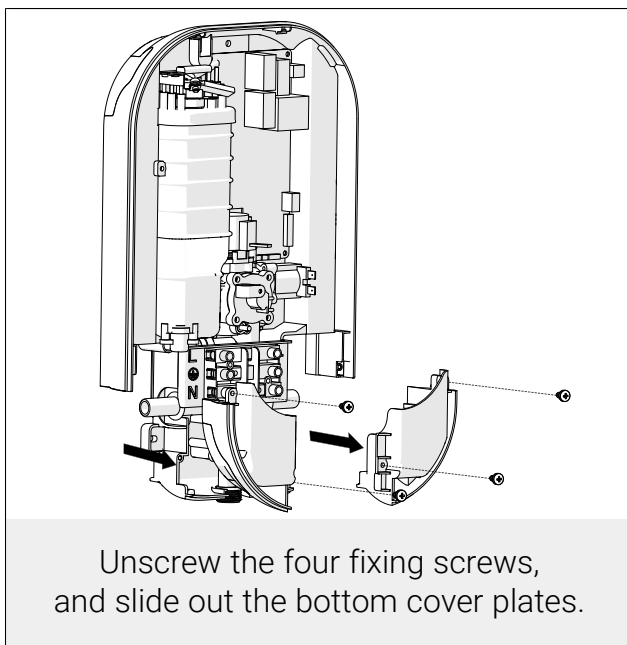

Unscrew the four fixing screws, and slide out the bottom cover plates.

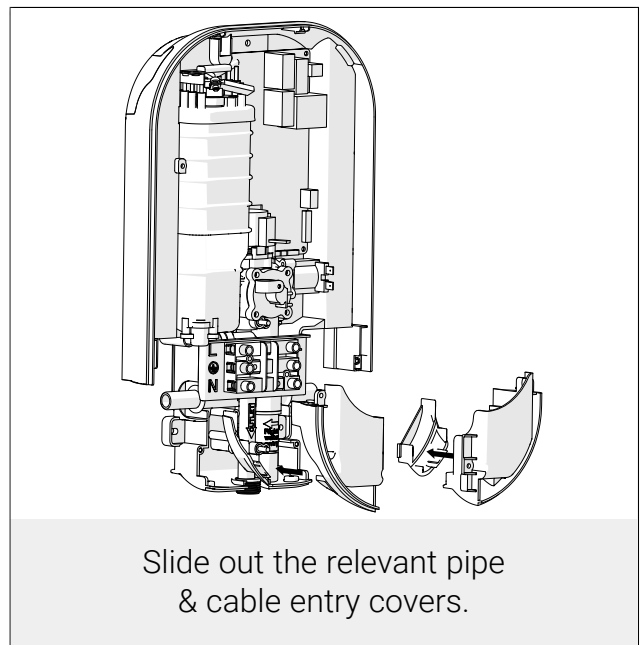

Slide out the relevant pipe & cable entry covers.

Fitting to Wall - Without Fitting Plate



It is essential to remove any debris and/or brick dust that could otherwise damage the unit. Do not make any alternative – as this may compromise safety and will invalidate the warranty. Check for hidden cables and water pipes.

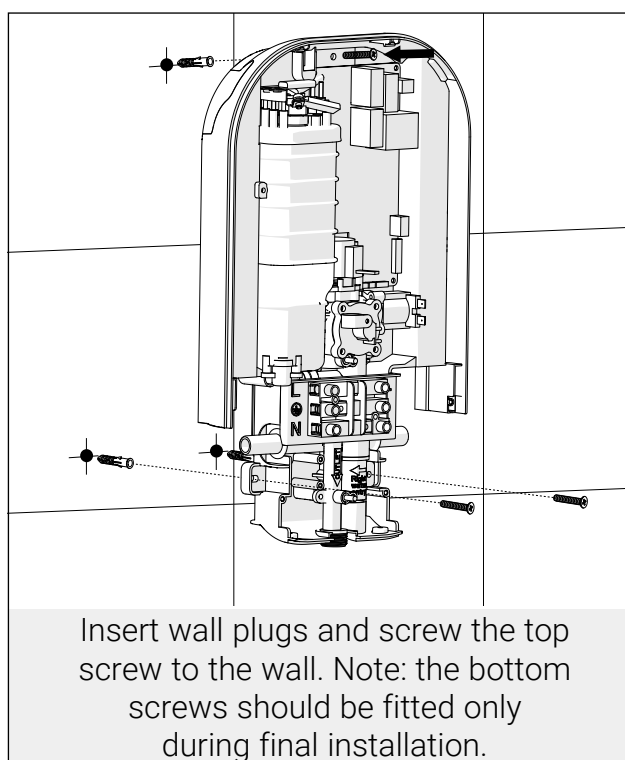
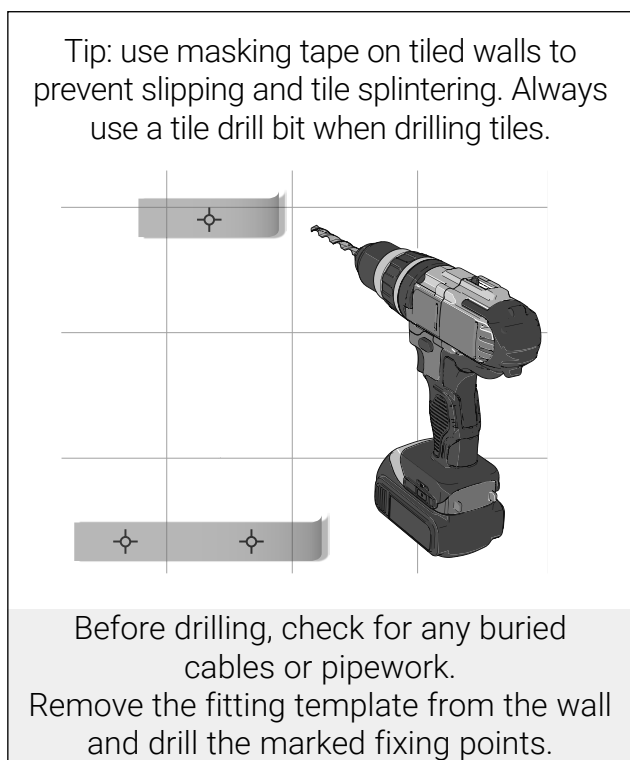
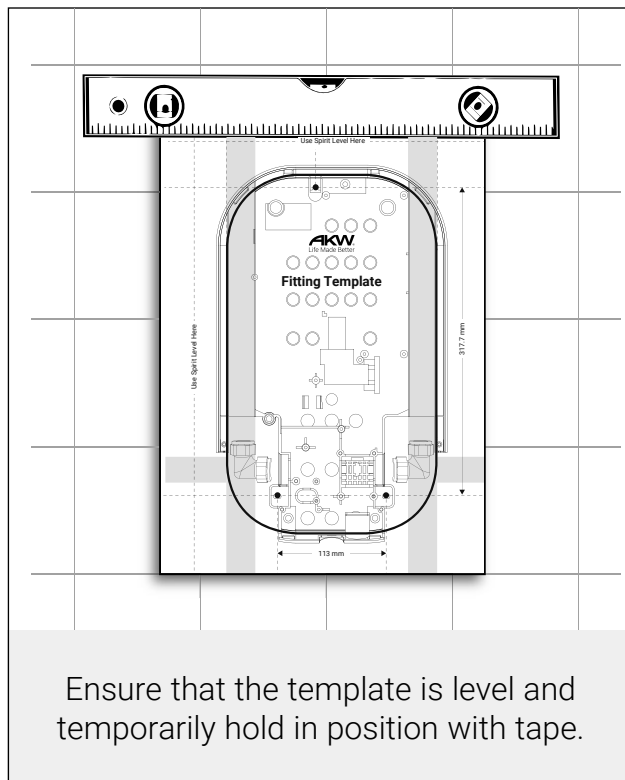
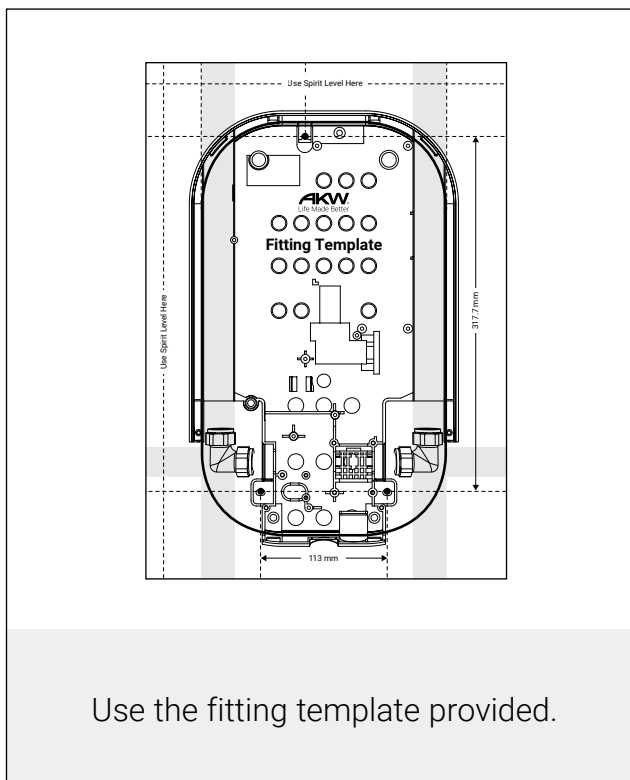

Fitting to Wall - With Fitting Plate

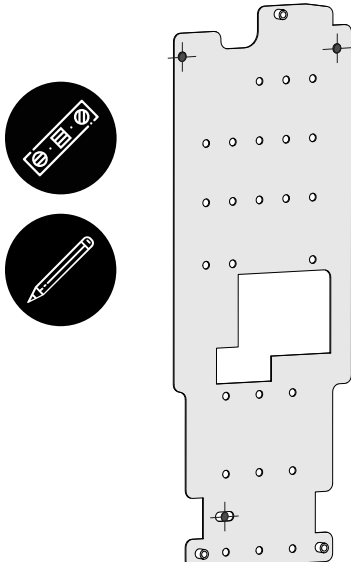

Ensure that the plate is level and mark a minimum of 3 out of the 28 available fixing points on the wall.

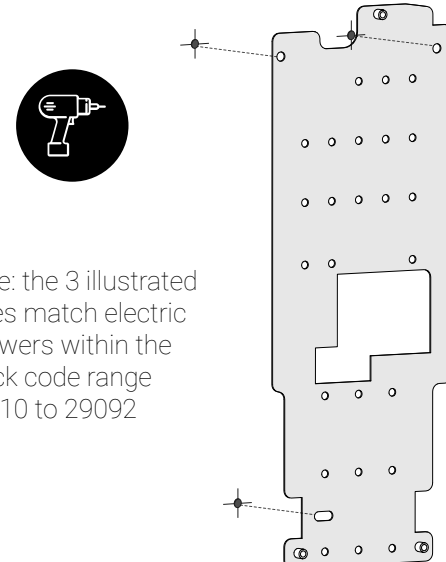

Note: the 3 illustrated holes match electric showers within the stock code range 29010 to 29092

Before drilling, ensure there are no cables or water supplies running within that area of the wall.

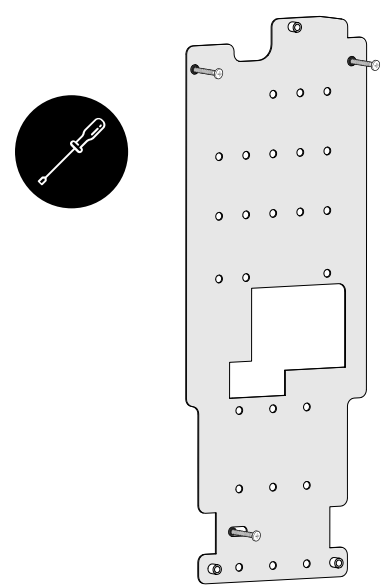

Drill, insert wall plugs and screw to wall.

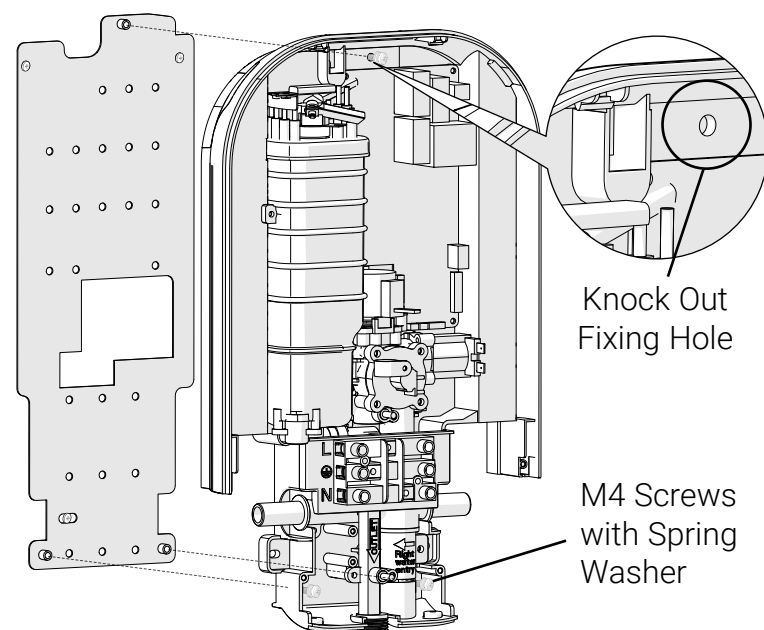

Knock Out Fixing Hole

M4 Screws with Spring Washer

Knock out the fixing hole at the top of the back case with a screwdriver, and screw back case to plate using the provided 3x M4 machine screws.

Reassembly - Bottom Cover

REASSEMBLY - BOTTOM COVER

Once the cable and pipe connections have been made, reassemble the bottom cover plates.

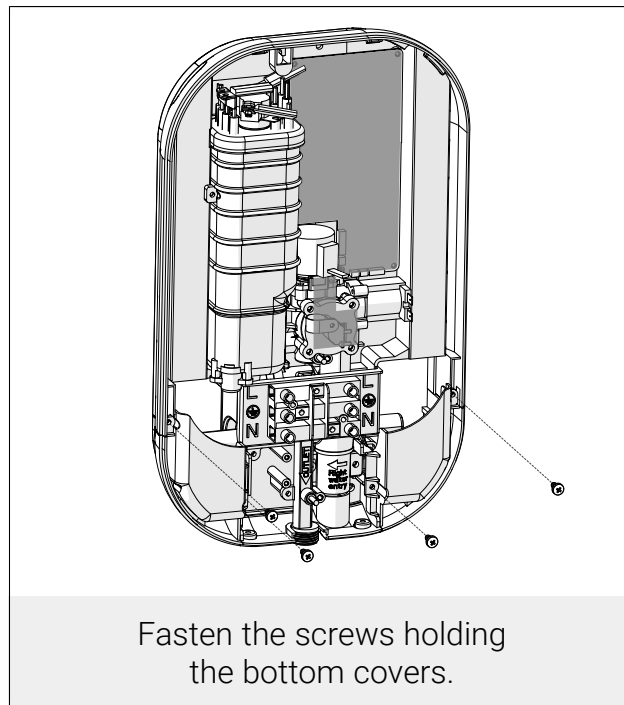
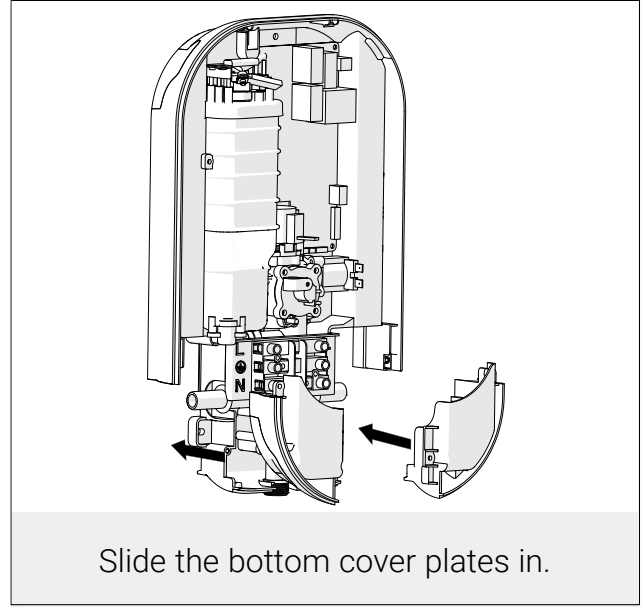
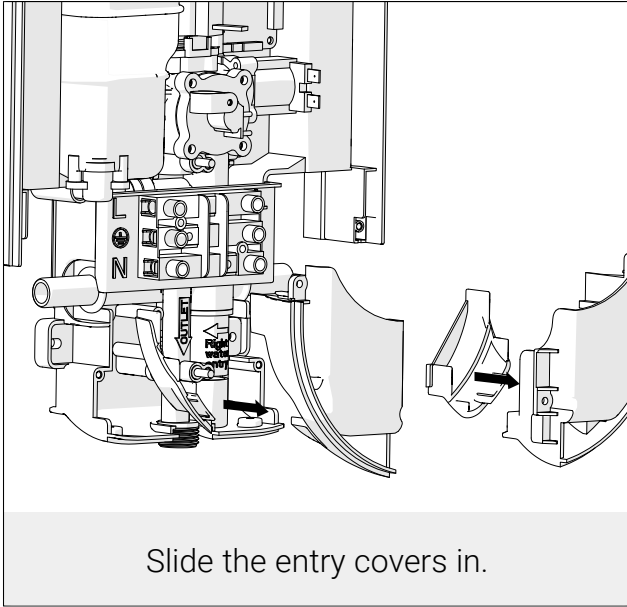

Reassembly - Front Cover

Ensure that all connectors are correctly inserted before the cover is refitted.

Refit the Front Cover taking care not to trap the ribbon cable or any other wires.

Use only the supplied screws to secure the front cover. Failure to do so may cause internal damage to the appliance.

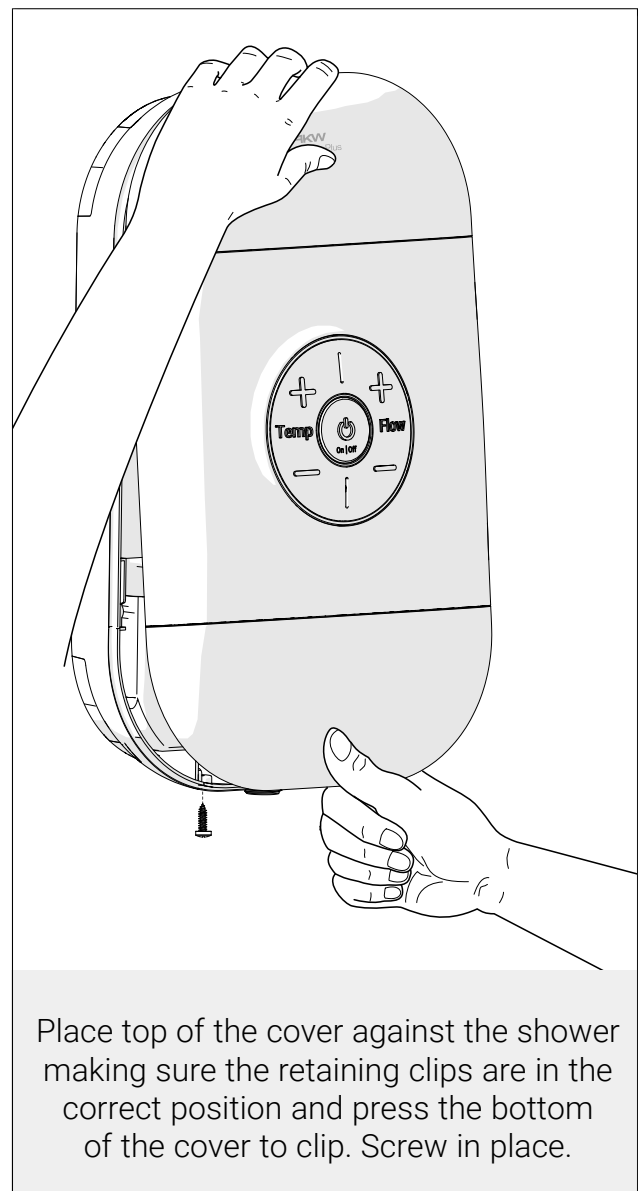
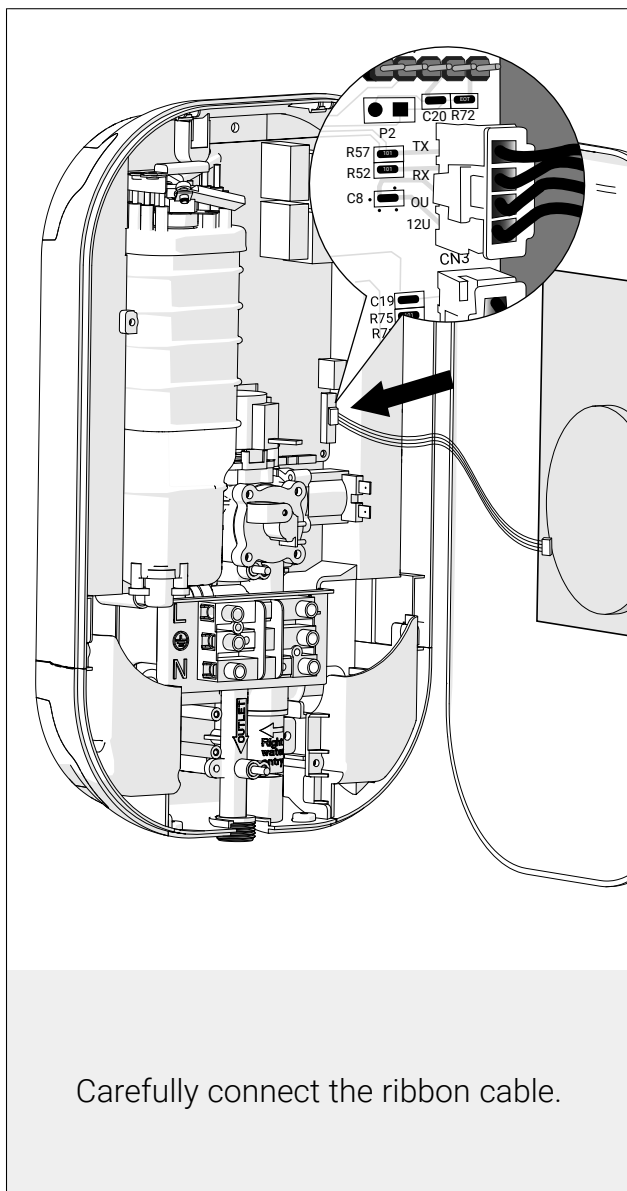

COLD WATER FEED ONLY - Never fit the appliance to the hot water supply.

There are 6 water inlet points for easy installation.

Plumbing work should be completed before any electrical connections are made.

Before assembly, flush the water supply pipes thoroughly to remove debris in the pipework (allow the water to run with the main stopcock open for about 3 mins), to prevent debris and dirt particles from blocking the filter which might affect the function of the shower.

DO NOT fit any form of outlet flow control to the water heater.

Note: An isolating stop valve must be installed on the cold water feed before connecting to the shower. The isolation valve (not supplied) should be fitted as close as is practicable to the water supply inlet of the shower heater whilst being accessible for maintenance and servicing purposes.

Remove retaining screw and rotate inlet valve to left or right as desired.

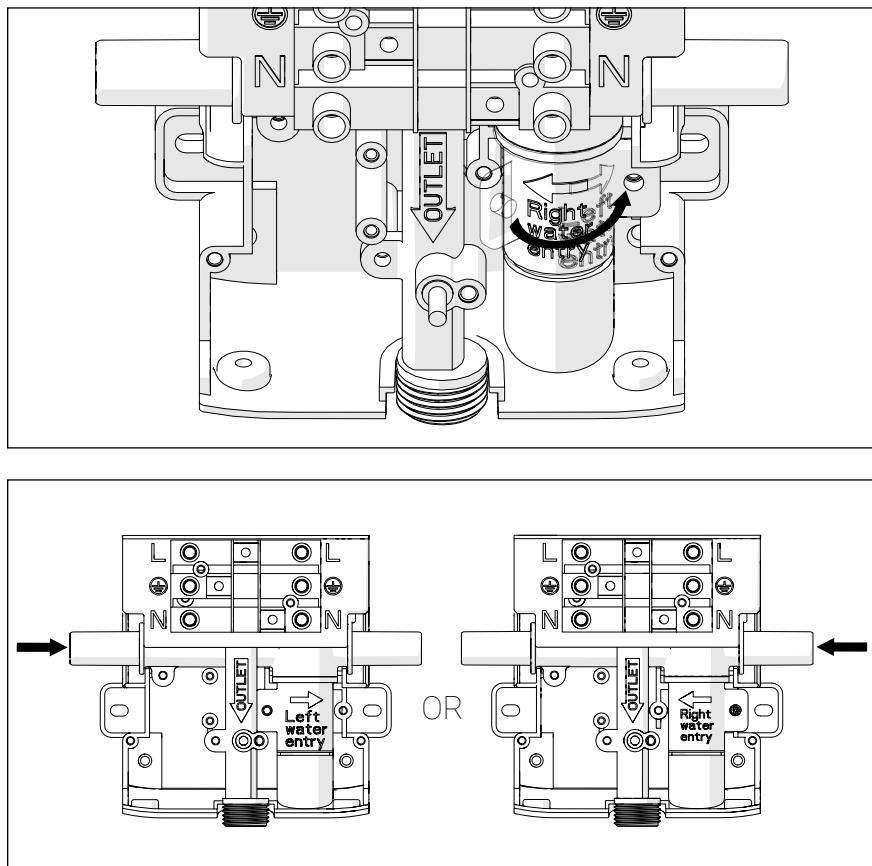

Determine pipework position and select the inlet option most suited to your situation. Always prime pipework and flush clear of debris.

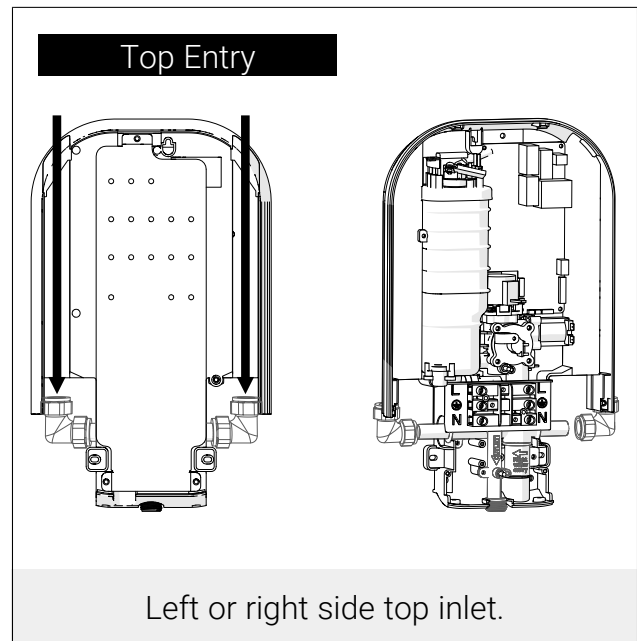
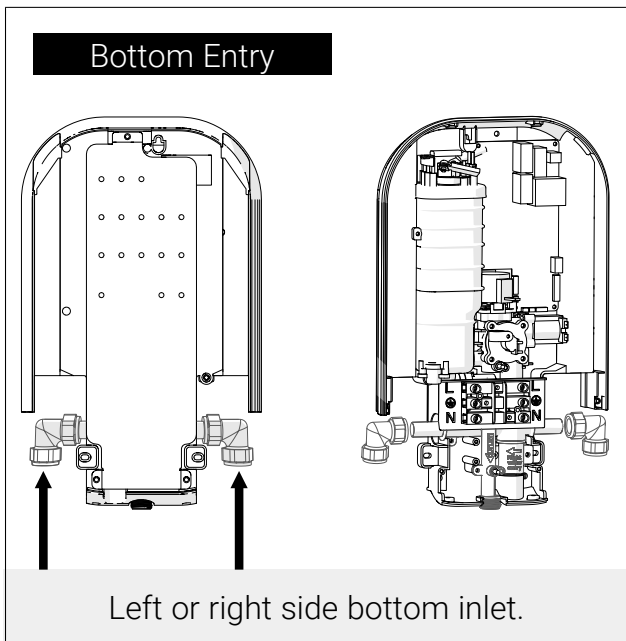
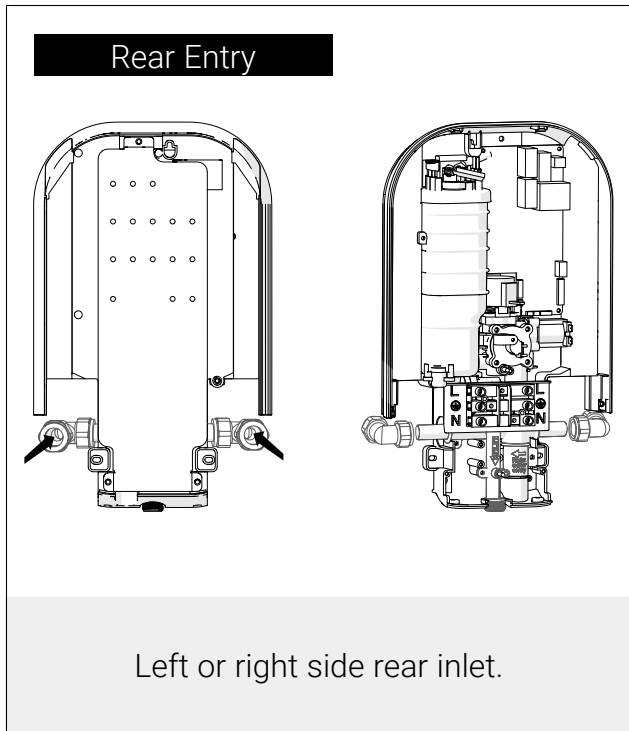

Note: Some water from the factory testing may escape when the bottom blanking plug is removed.



Caution - Danger of Death 230 V AC
Lethal Voltage present on the AC supply.

WARNING - THIS APPLIANCE MUST BE EARTHED

ALL COMPONENTS MUST BE RATED AND INSTALLED IN ACCORDANCE WITH WIRING REGULATIONS.

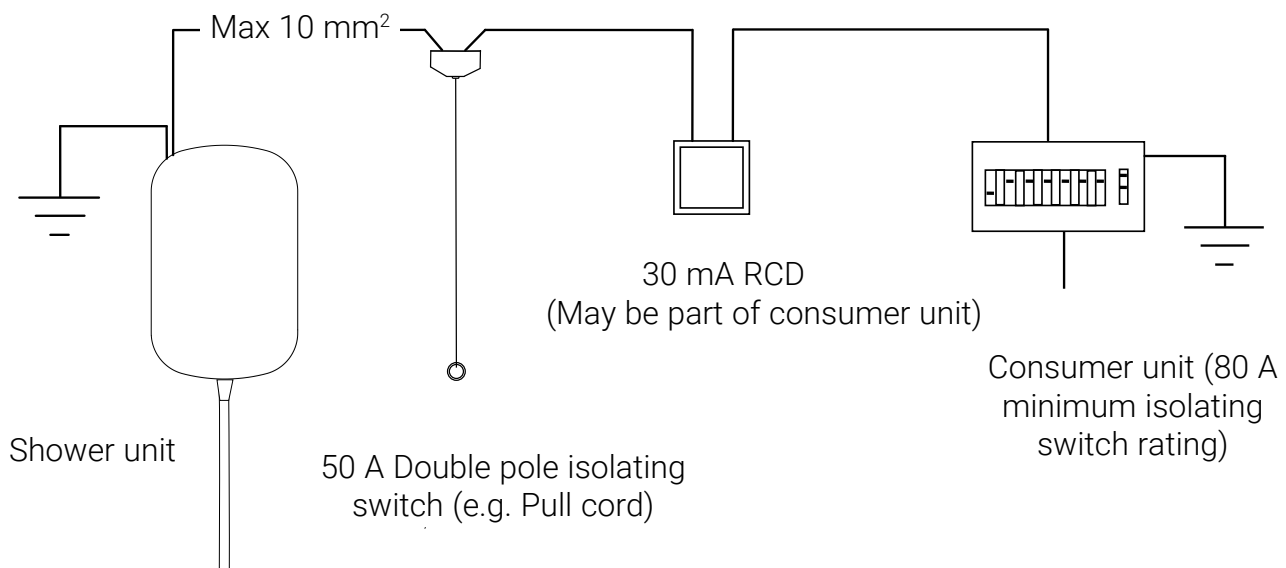

For adequate circuit protection DO NOT use a rewirable fuse. Instead use a suitably rated miniature circuit breaker or cartridge fuse.

A 30 mA residual current device (RCD) must be installed.

A 50 amp double pole isolating switch with a minimum contact gap of 3 mm in both poles must be incorporated in the circuit.

The isolating switch must have a mechanical indicator showing when the switch is in the OFF position, and the wiring must be directly connected to the switch.

The isolating switch must be accessible and clearly identifiable, although out of reach of a person using a fixed bath or shower. The cord of a cord-operated switch should be placed so that it is not possible to touch the switch body whilst standing in a bath or shower cubicle.

Where shower cubicles are located outside of a bathroom, all socket outlets in the room must be protected by a 30 mA RCD. Consult the wiring regulations.

It is recommended to use the shortest cable route possible from the consumer unit to the shower.

Determine cable entry position

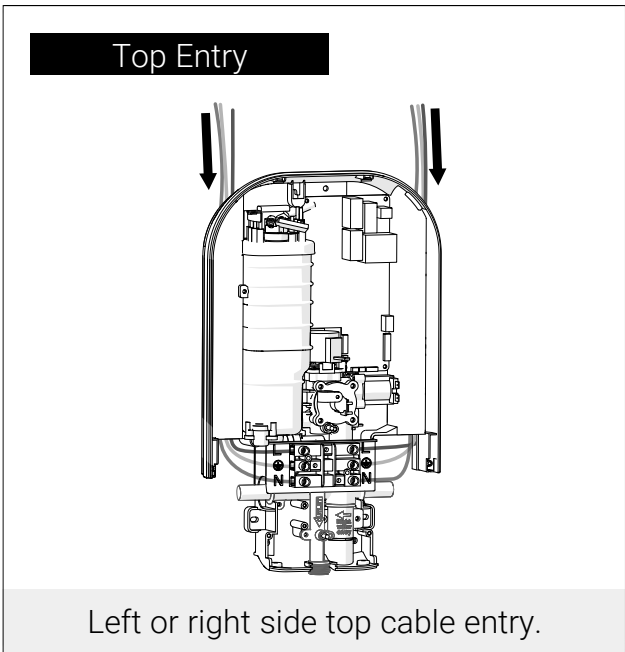
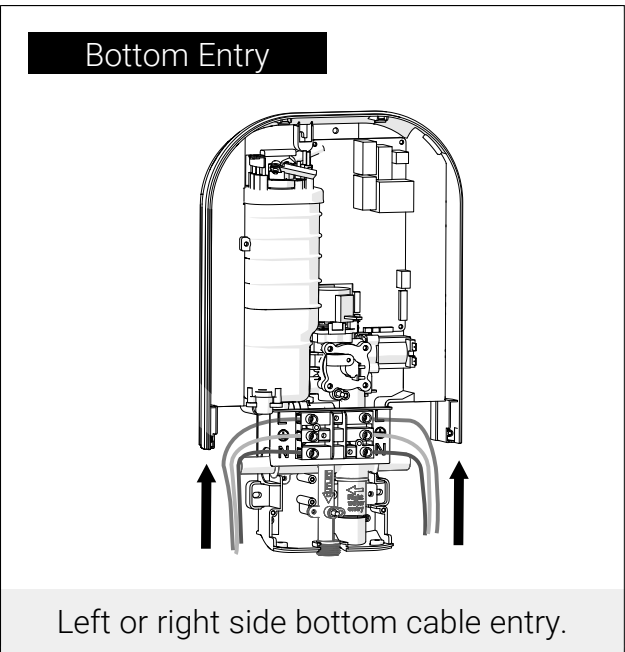
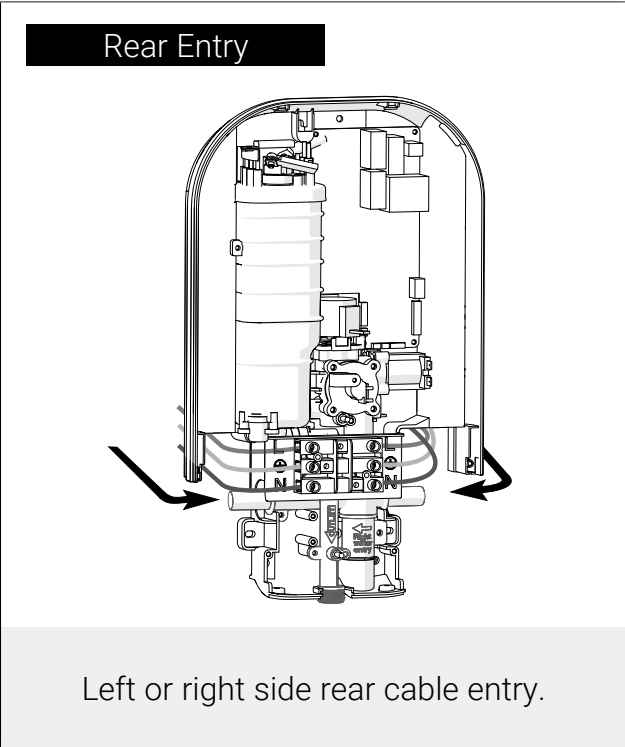

IMPORTANT

Connect to only the left OR right terminal blocks.

Never make a simultaneous connection to both left and right terminal blocks.

Trim and replace pipe and cable entry covers.

Note: Depending on cable size and entry point used, it may be necessary to strip back the outer cable sheath sufficiently to allow cables to be directed to the terminal connection block within the unit.

Connecting Waste Pump

CONNECTING WASTE PUMP

Connecting Waste Pump

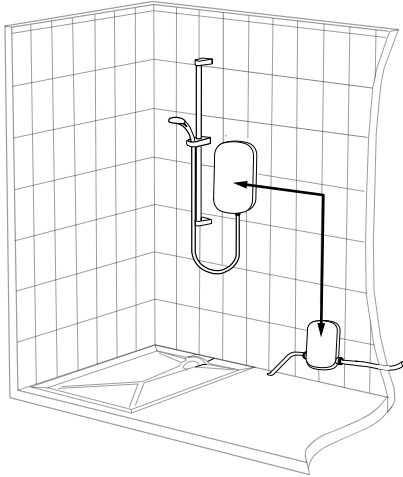

Wireless Pump Connection

A wireless pump connection module is available.
 Stock code 30315

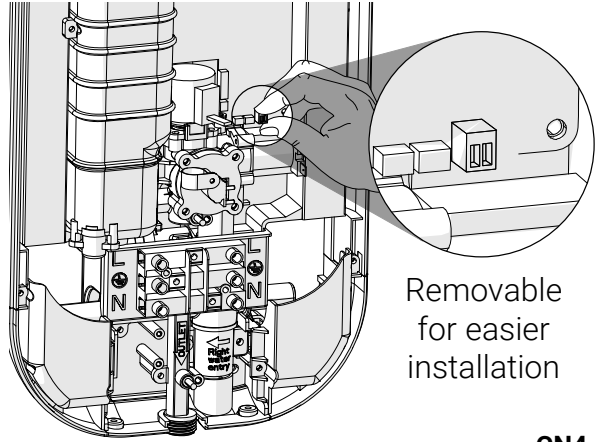

Removable for easier installation

Wired Pump Connection

See next page to set output at either pulsed or switched as desired.

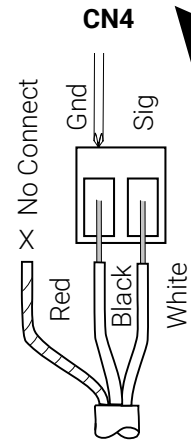

Factory Settings

The shower is set in its factory setting when packaged.

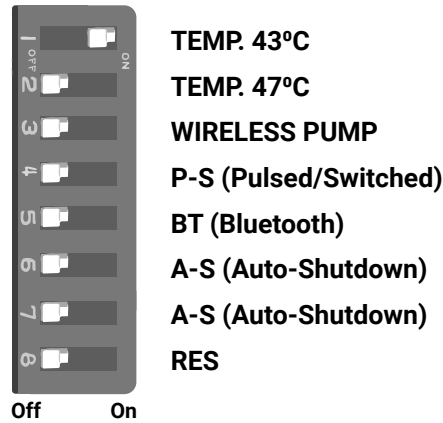

Temperature	Switch 1 OFF ON OFF ON	Switch 2 OFF OFF ON ON	Range 30-41°C 30-43°C 30-47°C 30-41°C
Pump Connection	Switch 3 OFF OFF ON ON	Switch 4 OFF ON OFF ON	Instruction Wired pump on: switched / wireless pump off Wired pump on: pulsed / wireless pump off Wireless pump on / wired pump off Wireless pump on / wired pump off
Bluetooth	Switch 5 OFF ON		Instruction Bluetooth disabled Bluetooth enabled
Auto-Shutdown	Switch 6 OFF ON OFF ON	Switch 7 OFF OFF ON ON	Duration 30 Minutes 20 Minutes 10 Minutes 5 Minutes

CARE beep: If DIP switch maximum temperature = 41°C then shower 'beeps' once when isolator switched on.

Functional Checks

Switch on the shower by pressing the power button.

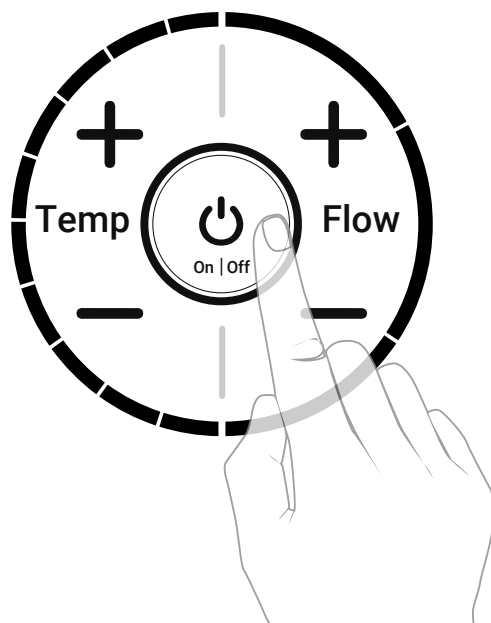

Confirm the operation of the Temperature and Flow increase and decrease buttons, whilst ensuring all LEDs are functioning.

Press the Power button to revert to standby mode.

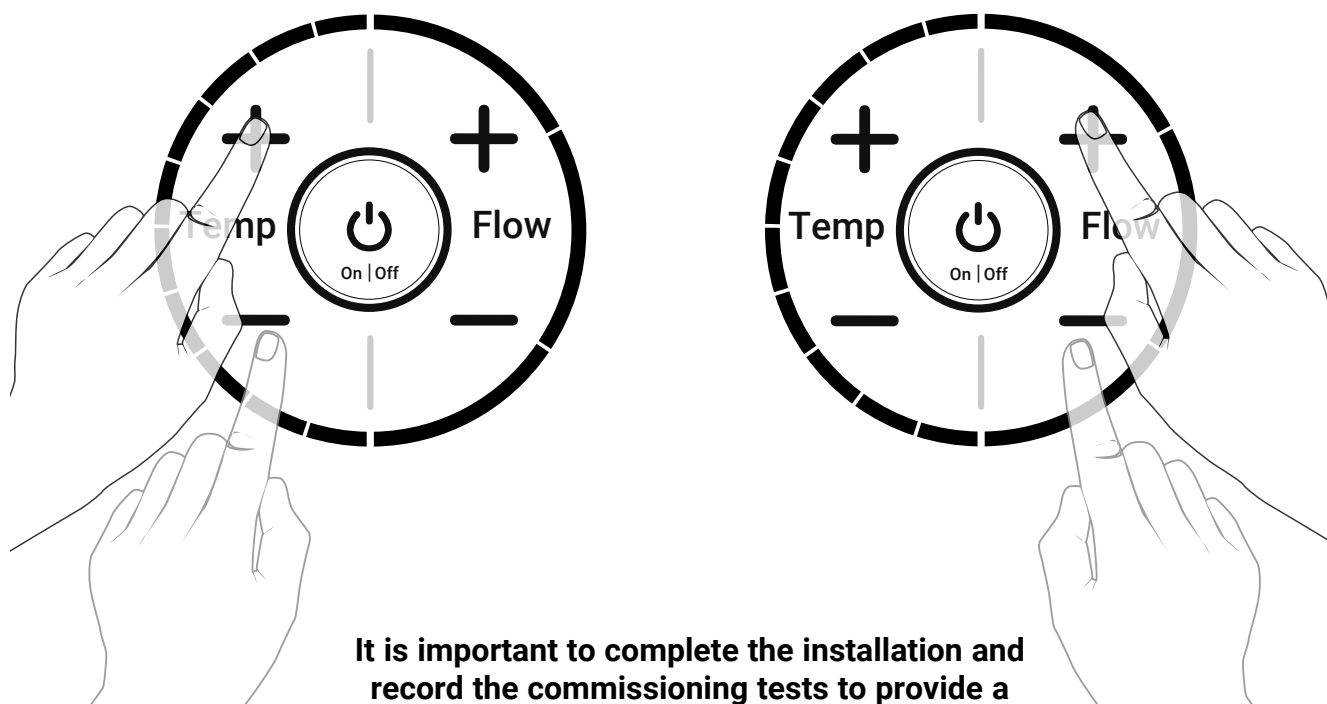

It is important to complete the installation and record the commissioning tests to provide a performance reference point for future tests.

Commissioning Procedure

With the shower electrical supply isolated, remove front cover and check that the maximum temperature switch (see page 23) matches the intended use; (eg 41°C BEAB Care).

With power applied to the shower:

Check that the terminal voltage at the shower is within the range 230 V +/- 10%.

With the shower electrical supply isolated, refit front cover.

With power applied to the shower:

Turn on the shower and enter 'Cold Water Flushing' mode (see page 6)

Check that inlet water supply temperature is within the range, 3 to 28°C (5 to 20°C BEAB Care);

Exit cold water flushing when completed

Turn on the shower and use the temperature controls to set the outlet water temperature to maximum, and the flow controls to set the flow rate to maximum. Then carry out the following sequence:

Record the outlet water temperature and flow rate;

Reduce the water supply flow rate at the inlet of the shower to 2.5 lpm;

Record the outlet water temperature at the reduced flow rate;

The outlet water temperature should not exceed the maximum temperature switch setting (see page 23).

Record details of test equipment (thermometer, voltmeter, flow meter etc.) used for the measurements.

In-Service Tests

In-Service Tests

The purpose of in-service tests is regularly to monitor and record the performance of the shower. Deterioration in performance can indicate the need for service work on the shower and/or the water supplies.

Procedure

Using measuring equipment to the same specification as used in commissioning the shower, check that:

The water supply temperature is within the range; 3 to 28°C (5 to 20°C BEAB Care);

The terminal voltage at the appliance is within the range 230V +/- 10%;

If the maximum outlet water temperature has changed by more than 1°C from the previous test results, record the change and check:

- for any damage/blockage to the shower, inlet filter, hose and handset;
- any in-line or integral check valves or other backflow prevention devices are in good working order;
- any isolating valves are fully open.

With an acceptable outlet water temperature, complete the following procedure:

Record the outlet water temperature and the flow rate at maximum settings;

Reduce the water supply flow rate at the inlet of the shower to 2.5 lpm;

Record the outlet water temperature

Record details of test equipment (thermometer, voltmeter etc.) used for the measurements.

If an acceptable outlet water temperature cannot be achieved i.e. temperature is greater than the maximum temperature switch setting (see page 23) by +1° or more then service work is required.

Measuring flow rate

With the shower handset connected, using a measuring jug, collect 1 litre of water and time how long this takes.

60 Divided by the time taken = Flow Rate LPM

e.g. 60 Divided by 20 seconds = 3 LPM

Frequency of in-service tests

Following the commissioning of the shower, or any significant repair, the installation should be re-tested within a 6-8 week period.

If no significant changes (eg less than 1°C) in outlet water temperatures are recorded between tests, then the next in-service test can be deferred to 24-28 weeks.

If there is a significant change then contact AKW Technical Enquiries.

Contact Us

AKW
Life Made Better

Orders & Quotes

01905 823 299
orders@akw-ltd.co.uk

General Enquiries

01905 823 298
sales@akw-ltd.co.uk

Technical Enquiries

01905 560 219
tech@akw-ltd.co.uk

Kitchen Enquiries

01905 823 262
kitchens@akw-ltd.co.uk

Fax

01905 823 297

AKW

Pointon Way, Hampton Lovett
Droitwich Spa, WR9 0LR

www.akw-ltd.co.uk
orders.akw-ltd.co.uk

Follow us on Social:



Warranty

Warranty applies only to manufacturing or material defects, conditional on the one-time correct installation of the product. It does not apply to:

- Inappropriate use or accidental damage.
- Damage or defects that result from incorrect installation.
- Lack of maintenance including the build up of grime or damage resulting from inappropriate cleaning.
- Damage or defects that result from repairs or modifications undertaken by unauthorised persons.
- General wear and tear through usage and does not apply to surface finishes.

Warranty period starts from the date of installation. To activate your warranty, you must register your product within 30 days of installation. See the T&Cs on our website for further information.

Select 1 of 3 ways to activate your warranty



1. Scan using your Smart Device

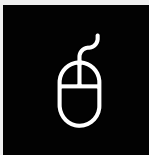

2. Visit Online

akw-ltd.co.uk/warranty-information



3. Warranty Card

Fill and complete warranty card and post using the prepaid envelope supplied

What to do if something goes wrong?

In the event that you encounter a problem with this product, follow the trouble shooting guide if applicable, then contact your local installer. If the issue is still unresolved, contact AKW Technical Enquiries who will provide further advice and arrange for a maintenance engineer to visit if necessary. None of the foregoing affects your statutory rights.