

# Company Presentation

Since 1870

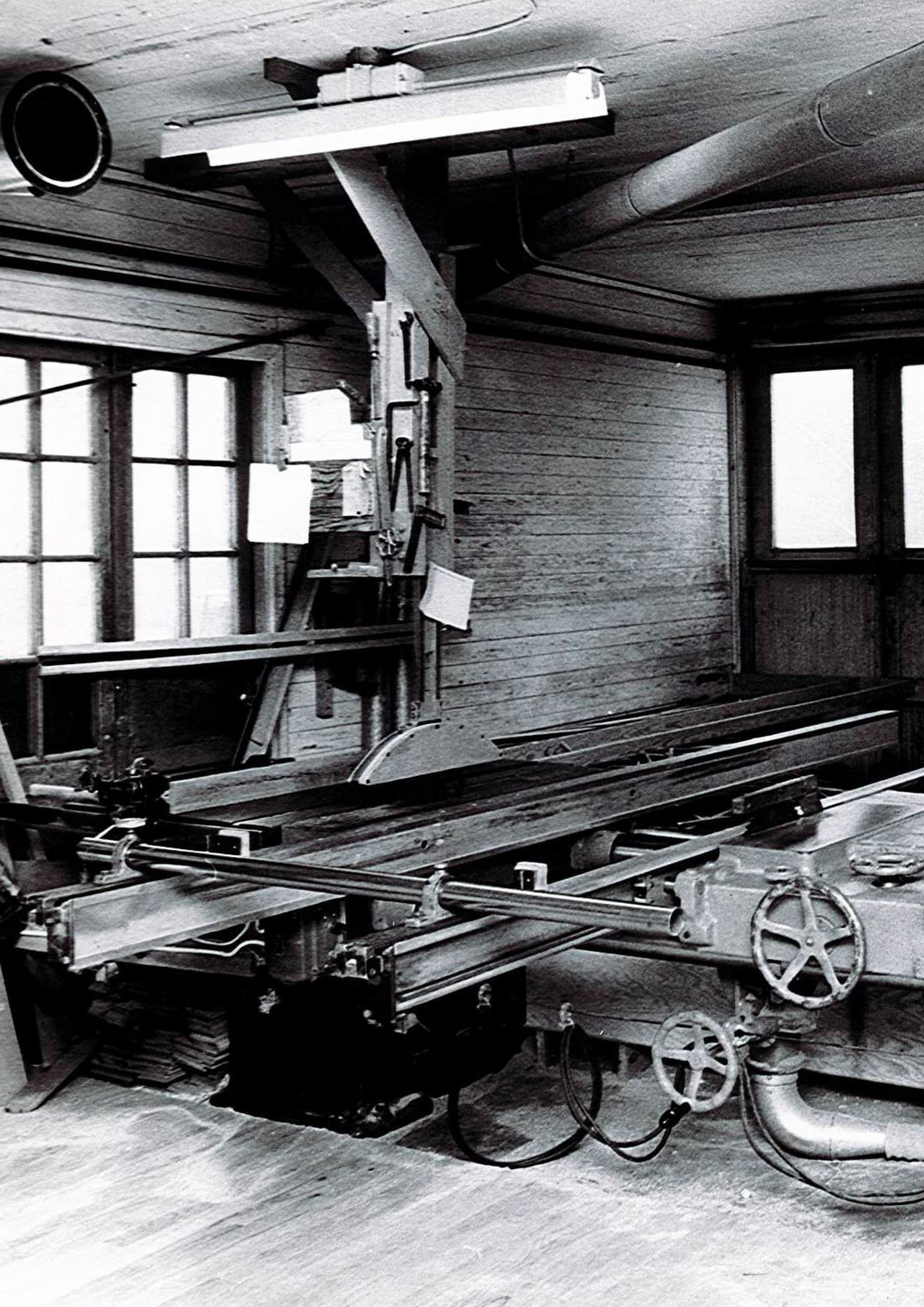



# CONTENT

---

Our History	4
Our Market	8
Quality   Environment	10
Our Manufacturing	12
Safety   Warranty	14
Product Development   Support/Service	16
Applications for Our Products	18
CAD Files   Our Videos	20
Product Range	22



# Our History

Follow our journey from a small carpentry workshop to a world-leading supplier of accessibility-adapted products.



1870

The story began as early as 1870 when Otto Granberg built his first chairs.

Business went well, and Otto's carpentry workshop started mass-producing furniture.

The factory soon expanded its range to include windows, doors, and stairs.



1960

Until 1960, Granberg was a carpentry company manufacturing windows, doors, and stairs.

At the request of a Swedish organization, we developed the first test kitchen for people with disabilities.

This kitchen was successful, and we began mass production of assisted kitchens.



In the mid-1970s, sales increased, and the business moved to larger factory premises, making our cabinet manufacturing more efficient.

We developed our first kitchen with motorized, height-adjustable cabinets.



Computerization of offices and production began.

We received our first inquiries from outside of Sweden and export sales started to Norway, Finland, and the Netherlands.



1990

The company moved to its current premises, and the production of cabinets ceases.

Manufacturing is now entirely focused on lift systems, lift systems were modified to fit all standard cabinets on the market.



2000

Granberg Germany is founded. Currently, three people work for the company, with a head office in Bielefeld.

Participation in the ZOW and Interzum trade shows yields results.

The Granberg brand becomes increasingly well-known in the kitchen industry worldwide.



The company celebrated 50 years of kitchen lift systems, design manufacture and production.

We are continuously working to raise awareness of adapted kitchens and bathroom solutions at some of the largest trade shows around the world.



The pandemic hits with full force.

We quickly adapted to a new way of working.

Participation in trade shows is halted. We further digitalize our operations.

The website becomes more important than ever, with increasing inquiries from all parts of the world.

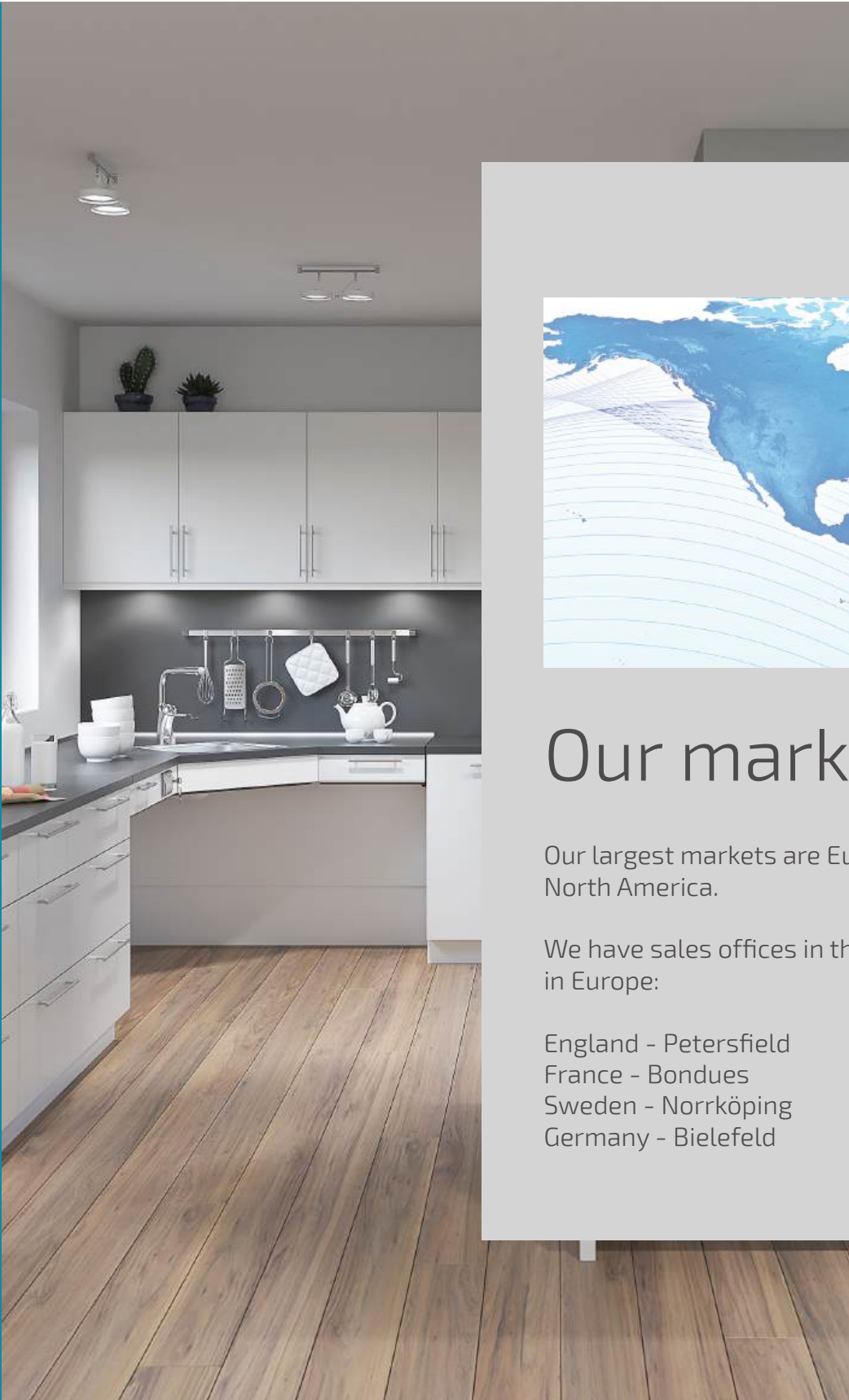

## Our market

Our largest markets are Europe, Australia, and North America.

We have sales offices in the following locations in Europe:

- England - Petersfield
- France - Bondues
- Sweden - Norrköping
- Germany - Bielefeld



Export Sales

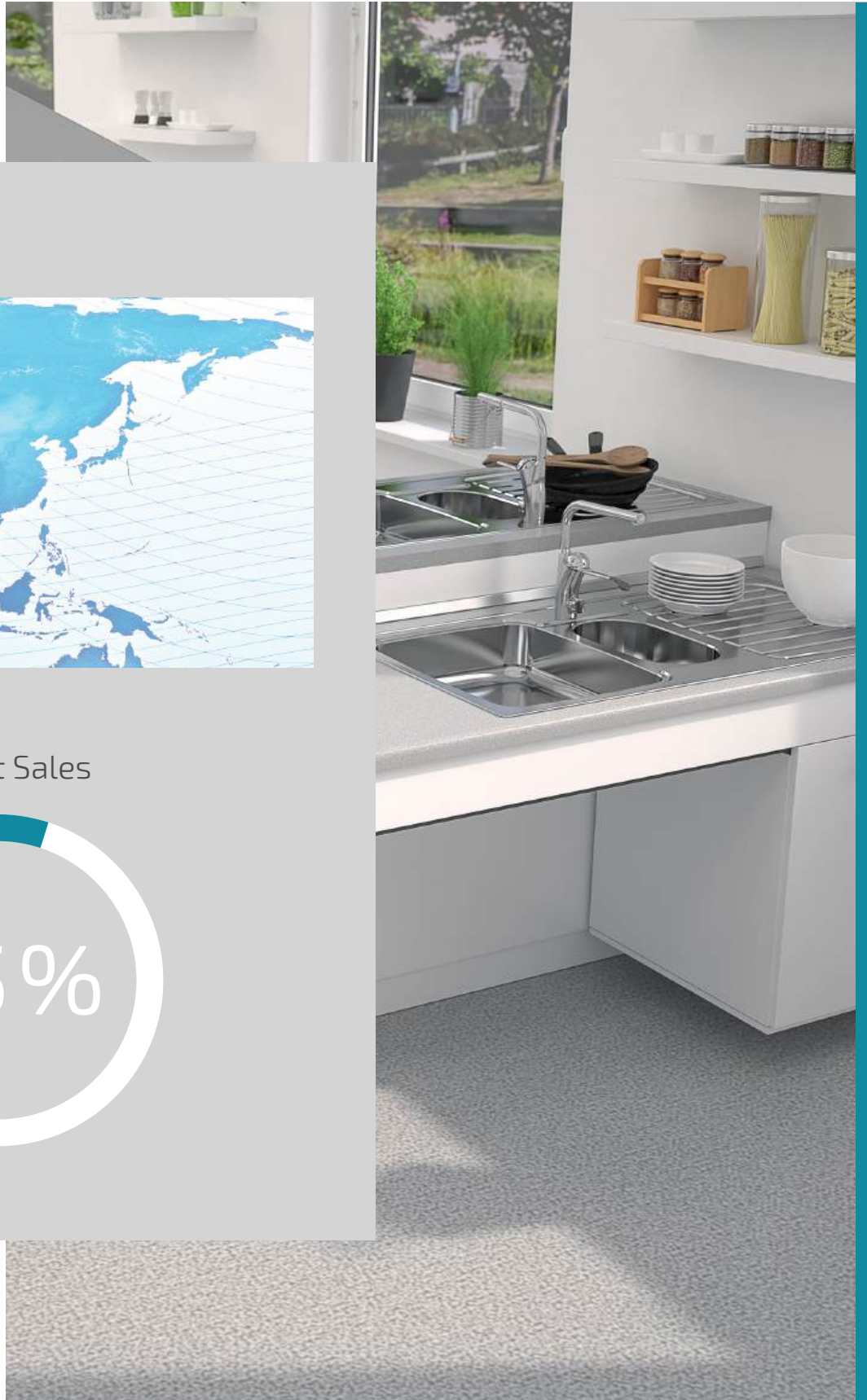
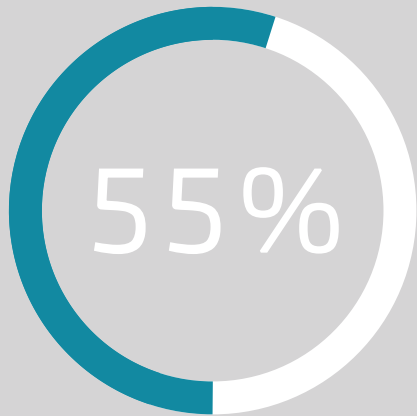



# Quality Policy

At Granberg, we are dedicated to providing the highest quality products possible to ensure the best experience for the customer, and we believe that every step of the customer journey should be enriching and satisfying.

Total quality reflects our approach to managing every aspect, from the sales inquiry to the assembly and delivery of our products.

We take pride in delivering prompt and precise responses to all inquiries. The customer experience is our top priority across the company. Every team member is actively engaged in our ongoing efforts to enhance our environmental and quality systems.

In our efforts to minimize environmental impact, we focus on product development and marketing strategies. We always strive to deliver the right product at the right time and in the right place.

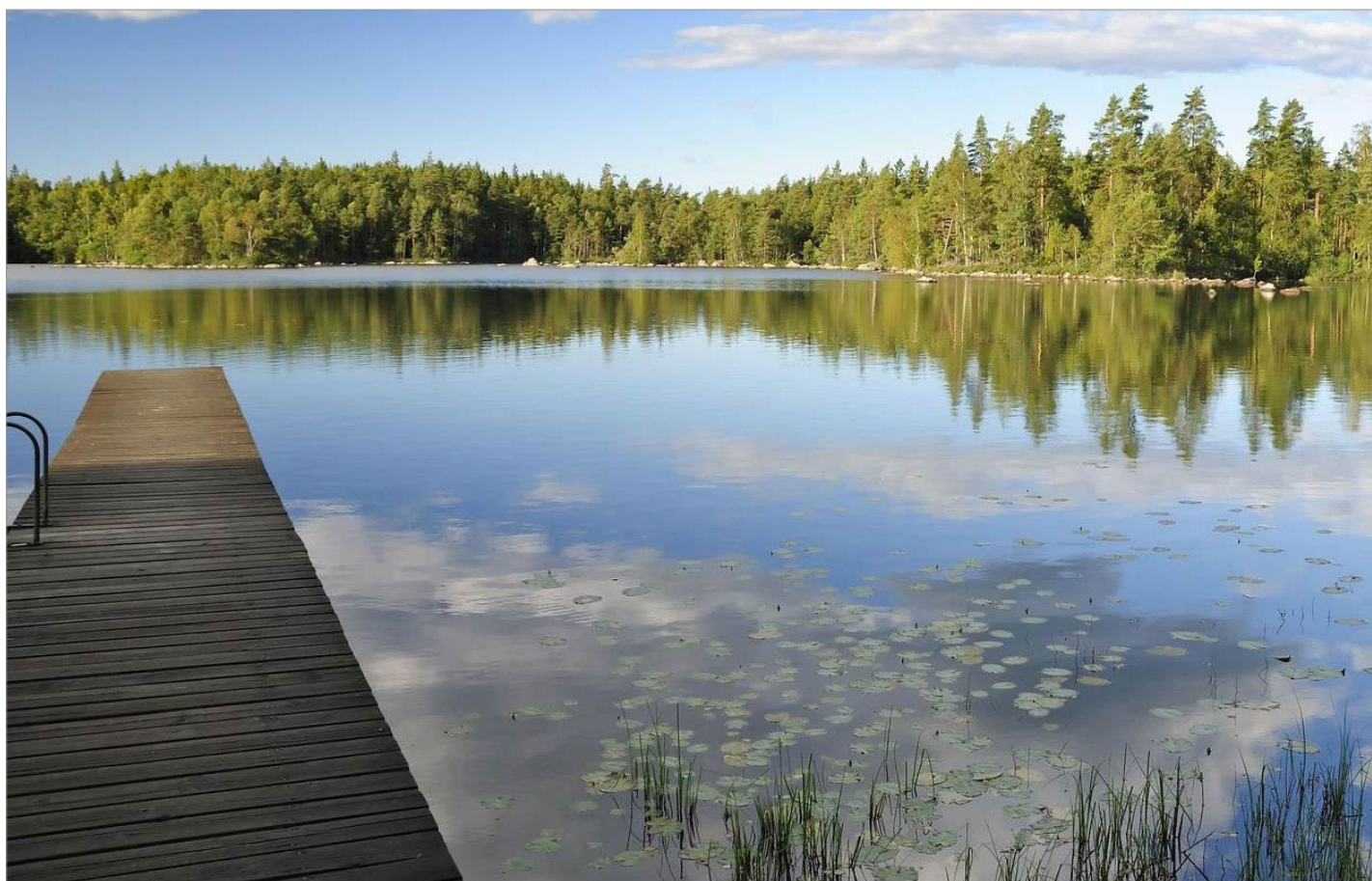

# Environmental Policy

At Granberg, we continuously assess and enhance our environmental initiatives within our manufacturing and development processes, all while upholding our tradition of quality craftsmanship.

We will:

- Value our business partners dedication to environmental sustainability.
- Develop products with minimal environmental impact during manufacturing, use, and disposal.
- Minimize negative environmental impact through preventive and continuous improvements.
- Use raw materials, water, and energy efficiently to reduce our environmental impact.
- Ensure the safety of our employees at our workplaces and promote a healthy attitude towards the environment in relation to our activities.
- Consider applicable laws, regulations, agreements, instructions, and rules as minimum requirements.



## Our Manufacturing

We manufacture all our products at our facilities in Norrköping. We have a network of suppliers mostly based in Sweden.

We have extensive experience in manufacturing and can adjust our capacity to meet customer needs.





# Safety

For your safety, we work exclusively with CE-marked lifting systems that have undergone risk analyses and testing.

Our lifting systems are based on thoroughly tested technology and feature built-in safety mechanisms that halt moving parts if an obstruction is detected.



# Warranty

Since 1870, when Otto Granberg founded our company, quality has been a cornerstone of our brand.

As a family-owned business, we take pride in the products we create. That's why we only deliver high-quality products that we have refined over many years and are confident in producing to the highest standards.

To give our customers even greater confidence in our products, we always offer a two-year warranty, for electric systems, please contact us for a quote to extend this up to 5 years.

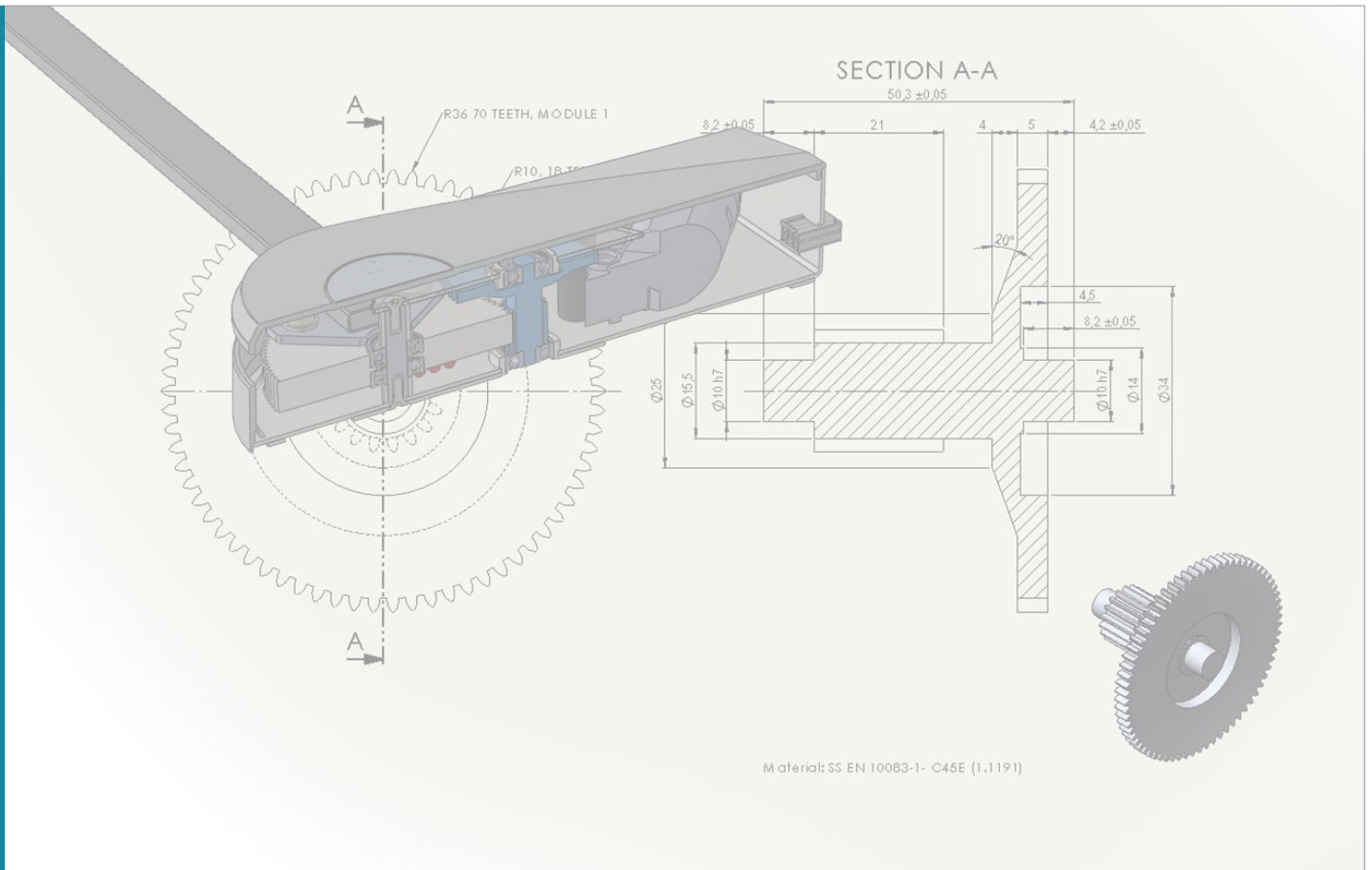

# Product Development

An important part of our operations is maintaining full control over our products and their quality.

We have our own modern product development department that works with the 3D software Solidworks.

Our close ties between sales/marketing and product development ensure that we stay at the forefront of developing/improving products according to customer needs.



## Support / Service

We believe it is important to provide the best possible support and customer service at all times before and after the sale.

Spare parts and expertise will be available for a long time, giving you, as a customer, the confidence and assurance in Granberg.



# Applications

Our products have a wide range of applications.

Examples of use cases include:

- Elderly care facilities
- Housing for individuals with disabilities
- Schools
- Hospitals / Training kitchens
- Private homes





# CAD-Files

Our BIM models make it easier for architects to specify our products in their projects.

The CAD symbols can be seamlessly integrated into drawings created in the most popular CAD systems used by architects.

Scan the QR code to view our CAD files.



**bimobject**<sup>®</sup>





# Videos

Our products are best described in motion, which is why we have many videos that make it easy to understand their functionality and installation process.

Scan the QR code to watch our videos.



# Accessible kitchens



# Product Collection

Examples of Our Kitchen Lifting Systems



## Verti 840

Lowers the shelf insert vertically down to the countertop



## Diago 504

Lowers one or more cabinets diagonally down and forward to the front edge of the countertop



## Baselift 6300

Electrically Height-Adjustable Straight Worktop Lift



## Centerlift 960

Electrically Height-Adjustable Kitchen Island

# Accessible closets



# Product Collection

Examples of Our Lifting Systems for Closets



## Butler 720

Electrically Height-Adjustable Clothes Rail



## Butler 722

Electrically Height-Adjustable Clothes Rail

# Accessible bathrooms



# Product Collection

Examples of Our Lifting Systems for Bathrooms



## Designline 417

Electrically Height-Adjustable Washbasin with integrated mirror



## Basicline 433

Electrically Height-Adjustable Washbasin with integrated mirror



## Basicline 415

Electrically Height-Adjustable Washbasin, Low Model



## Basicline 406

Gas-Spring Operated Height-Adjustable Washbasin Bracket

# Changing tables



# Product collection

Examples of our height adjustable changing tables



**Model 334 - Wall mounted**

Electric height adjustable changing table



**Model 333 - Free standing**

Electric height adjustable changing table



**Model 335 - Wall mounted**

Electric height adjustable changing table



**Model 345 - Free standing**

Electric height adjustable changing table



**GRANBERG**

**GRANBERG INTERIOR AB**  
Importgatan 30  
602 28 Norrköping  
Sweden  
Tel: +46 (0)11-19 77 50  
Email: [info@granberg.se](mailto:info@granberg.se)  
Internet: [www.granberg.se](http://www.granberg.se)

**GRANBERG UNITED KINGDOM**  
Bellamy House Winton Road  
Petersfield, Hampshire GU32 3HA  
United Kingdom  
Tel: +44 (0)800 0470 027  
Email: [info@granberg-uk.co.uk](mailto:info@granberg-uk.co.uk)  
Internet: [www.granberg-uk.co.uk](http://www.granberg-uk.co.uk)

SINCE 1870

