

(EN) Mounting instruction

(DK) Monteringsvejledning

(DE) Montageanleitung

(FR) Notice de montage

(NL) Montage-voorschrift

(SV) Monteringsanvisning

(NO) Monteringsveiledning

(ES) Instrucciones de montaje

Subject to alteration without further notice · Ret til ændringer forbeholdes · Recht auf Änderungen sind vorbehalten
Nous nous réservons le droit d'apporter toutes modifications pour l'amélioration de nos produits sans préavis · Wijzigingen voorbehouden
Rätten till ändringar förbehålles · Vi forbeholder oss rett til endringer · Salvo variaciones



DK Ved dobbeltsidig montering anvendes M6 rustfri møtrikker (DIN 934 A2) og M6 skruer (DIN 84A A2) med en længde svarende til emnets tykkelse (xx) + 8 mm.

Ved montage i porøse byggematerialer forhør Dem i tvivlstilfælde hos en fagmand angående valg af korrekt dybel (udtrækskraft ≥ 2 kN).

Ved gipsplader eller lign. anbefales det, at håndgrebet fastgøres i en egnet bagvedliggende konstruktion.

DE Bei doppelseitiger Montage sollen M6 rostfreie Mutter (DIN 934 A2) und M6 Schrauben (DIN 84A A2) mit einer Länge entsprechend zur Dicke des Gegenstandes (xx) + 8 mm verwendet werden.

Bei einer Montage an Leichtbauwänden setzen Sie sich bitte mit einem Fachmann zwecks Dübeltypen in Verbindung (Auszugskraft ≥ 2 kN)

Bei Gipswänden oder dergl. empfehlen wir die Berücksichtigung einer Vorwandinstallation.

EN When double mounting, stainless M6 nuts (DIN 934 A2) and M6 screws (DIN 84A A2) with a length corresponding to the thickness of the subject (xx) + 8 mm ($\frac{3}{8}$ ") must be used.

When mounting it is recommended, when in doubt, to check with a professional which type of fixing to use (extracting force ≥ 2 kN)

On plasterboard or equivalent we recommend that the handrail is secured to a suitable, underlying substrate.

FR Pour montage double utilisez des M6 écrous inoxydables (DIN 934 A2) et des M6 vis (DIN 84A A2) avec une longueur correspondant à la grosseur de la pièce (xx) + 8 mm.

Dans le cas de l'installation dans des matériaux de construction poreux, renseignez-vous, en cas de doute, auprès d'un spécialiste concernant le choix des chevilles correctes (force d'extraction ≥ 2 kN) Pour des carreaux de plâtre ou similaire nous recommandons que la barre d'appui soit fixée sur un renfort de cloison.

NL Bij rug-aan-rug montage dienen RVS M6 bouten (DIN 934 A2) en M6 schroeven (DIN 84A A2) met een lengte van de dikte van het onderdeel (xx) + 8 mm toe past te worden.

Win in twijfelgevallen bij montage in poreuze bouwmaterialen advies in bij een vakman over de keuze van de juiste plug (uittrekkraft ≥ 2 kN)

Bij toepassing van gipswanden of andere zwakke wanden dienen de handgreben op een goede onderliggende konstruktiegemonteerd te worden.

ES Tratándose de montaje bilateral se utilizan tuercas inoxidable M6 (DIN 934 A2) y tornillos M6 (DIN 84A A2) de una longitud correspondiente al espesor de la pieza (xx) + 8 mm.

Para el montaje en paredes porosas consulte a un profesional en caso de duda respecto al tipo de taco que se debe usar (esfuerzo de arranque ≥ 2 kN)

Tratándose de placas de yeso o similar se recomienda fijar el asidero con una construcción apropiada por detrás.

SV Vid dubbelsidig montering används M6 rostfria muttrar (DIN 934 A2) och M6 skruvar (DIN 84A A2) med en längd som motsvarar ämnets tjocklek (xx) + 8 mm.

Vid montering i porösa byggmaterial bör du i tveksamma fall ta kontakt med en fackman beträffande val av rätt sprint (dragkraft ≥ 2 kN)

Vid montering på gipsskivor eller liknande rekommenderar vi att handtaget sätts fast på en lämplig bakomliggande konstruktion.

NO Ved dobbeltsidig montering brukes M6 rustfri muttere (DIN 934 A2) og M6 skruer (DIN 84A A2) med en lengde som svarer til tykkelsen på emnet (xx) + 8 mm.

Ved montering i porøse bygningsmaterialer bør du i tvilstilfeller forhøre deg med en fagmann om valg av korrekt dybel (uttrekkskraft ≥ 2 kN)







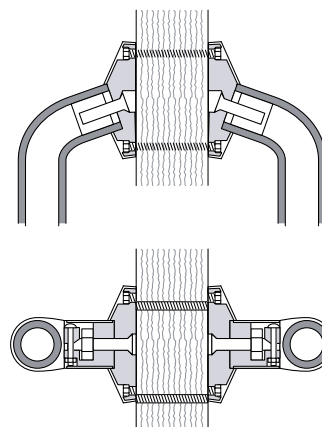

Ved gipsplater eller lign. anbefales det at man fester håndtaket i en bakenforliggende konstruksjon.

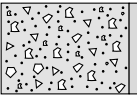
Ø 6 x min. 45 mm
Ø ($\frac{3}{8}$ ") x min. ($1\frac{1}{8}$ ")

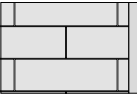
XX
+ 8 mm
($\frac{3}{8}$ ")

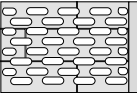
XX

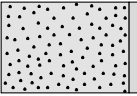
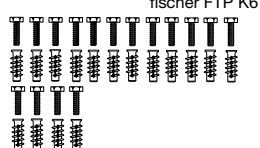
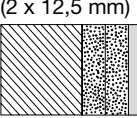
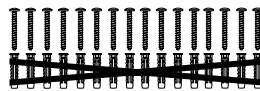
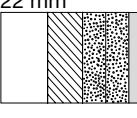
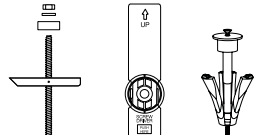
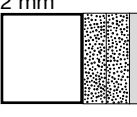
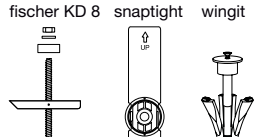
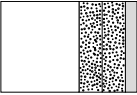

	(EN) Concrete >B25 (DK) Beton >B25 (DE) Beton >B25 (FR) Mur de béton >B25 (NL) Betonwanden >B25 (SV) Massiv betong >B25 (NO) Betonveg >B25 (ES) Paredes de hormigón >B25	V8618 Ø5 x 50 fischer SX 8 
	(EN) Solid Brick >= Mz12 (DK) Mursten >= Mz12 (DE) Vollstein >= Mz12 (FR) Brique pleine >= Mz12 (NL) Gemetselde wanden >= Mz12 (SV) Mursten >= Mz12 (NO) Mursteinsvegger >= Mz12 (ES) Paredes de ladrillo >= Mz12	V8618 Ø5 x 50 fischer SX 8 
	(EN) Solid Sand Lime Brick >= Hlz12 (DK) Kalksten >= Hlz12 (DE) Massiver Kalksandstein >= Hlz12 (FR) Parpaing plein >= Hlz12 (NL) Kalksteen >= Hlz12 (SV) Cementsten >= Hlz12 (NO) Massiv kalksandstein >= Hlz12 (ES) Caliza >= Hlz12	V8618 Ø5 x 50 fischer SX 8 
	(EN) Aerated Concrete P4 (DK) Gasbeton P4 (DE) Gasbeton P4 (FR) Béton cellulaire P4 (NL) Gasbeton P4 (SV) Lättbetong P4 (NO) Gassbetong P4 (ES) Paredes de hormigón poroso P4	V8668 M5 x 50 fischer FTP K6 
(2 x 12,5 mm) 	(EN) Drywall water-resistant, re-enforced with wood (DK) Gipsplader vandfast, med træforstærkning (DE) Gipsplatten wasserfest, mit Holz (FR) Plaque de plâtre imperméable, renforcée de bois (NL) Gipsplaten, watervast, versterkt met hout (SV) Godkända våtrumsskivor förstärkt med trä (NO) Gipsplater vannfast, med rupanel (ES) Pared de yeso impermeable, reforzamiento de madera	V8618 Ø5 x 50 fischer SX 8 
(2 x 12,5 mm) 22 mm 	(EN) Drywall water-resistant, re-enforced with plywood (DK) Gipsplader vandfast, forstærket med krydsfinér (DE) Gipsplatten wasserfest, versterkt mit Sperrholz (FR) Plaque de plâtre imperméable, renforcée de contreplaqué (NL) Gipsplaten, watervast, versterkt met hout (SV) Godkända våtrumsskivor förstärkt med kryssfänér (NO) Gipsplater vannfast, forsterket med kryssfänér (ES) Pared de yeso impermeable, reforzamiento de madera contrachapada	fischer KD 8 snaptight wingit 
(2 x 12,5 mm) 2 mm 	(EN) Drywall water-resistant, re-enforced with steel plates (DK) Gipsplader vandfast, forstærket med stålplader (DE) Gipsplatten wasserfest, versterkt mit Stahlplatten (FR) Plaque de plâtre imperméable, renforcée d'acier (NL) Gipsplaten, watervast, versterkt met staal (SV) Godkända våtrumsskivor förstärkt med stål (NO) Gipsplater vannfast, forsterket med stålplater (ES) Pared de yeso impermeable, reforzamiento de placa de acero	fischer KD 8 snaptight wingit 
(2 x 12,5 mm) 	(EN) Drywall water-resistant (DK) Gipsplader vandfaste (DE) Gipsplatten wasserfest (FR) Plaques de plâtre imperméables (NL) Gipsplaten, watervast (SV) Godkända våtrumsskivor (NO) Gipsplater vannfast (ES) Pared de yeso impermeable	

- (EN) Wall fixing kit not included.
 (DK) Skruer til vægmontering medfølger ikke.
 (DE) Wandbefestigung nicht enthalten.
 (FR) Les vis pour montage mural ne sont pas incluses
 (NL) Bevestigingsmateriaal voor de wand niet inbegrepen.
 (SV) Skruvar för väggmontering ingår ej
 (NO) Skruer for veggmontering er ikke inkludert
 (ES) Los tornillos montajes para la pared no están incluidos.

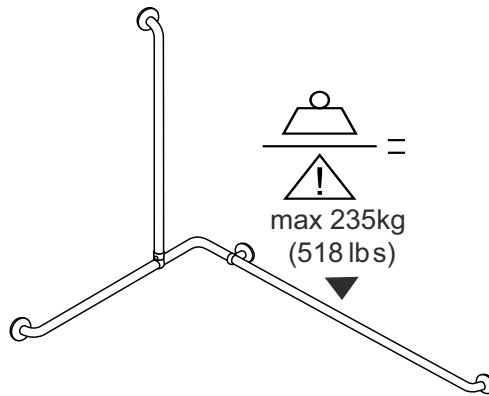

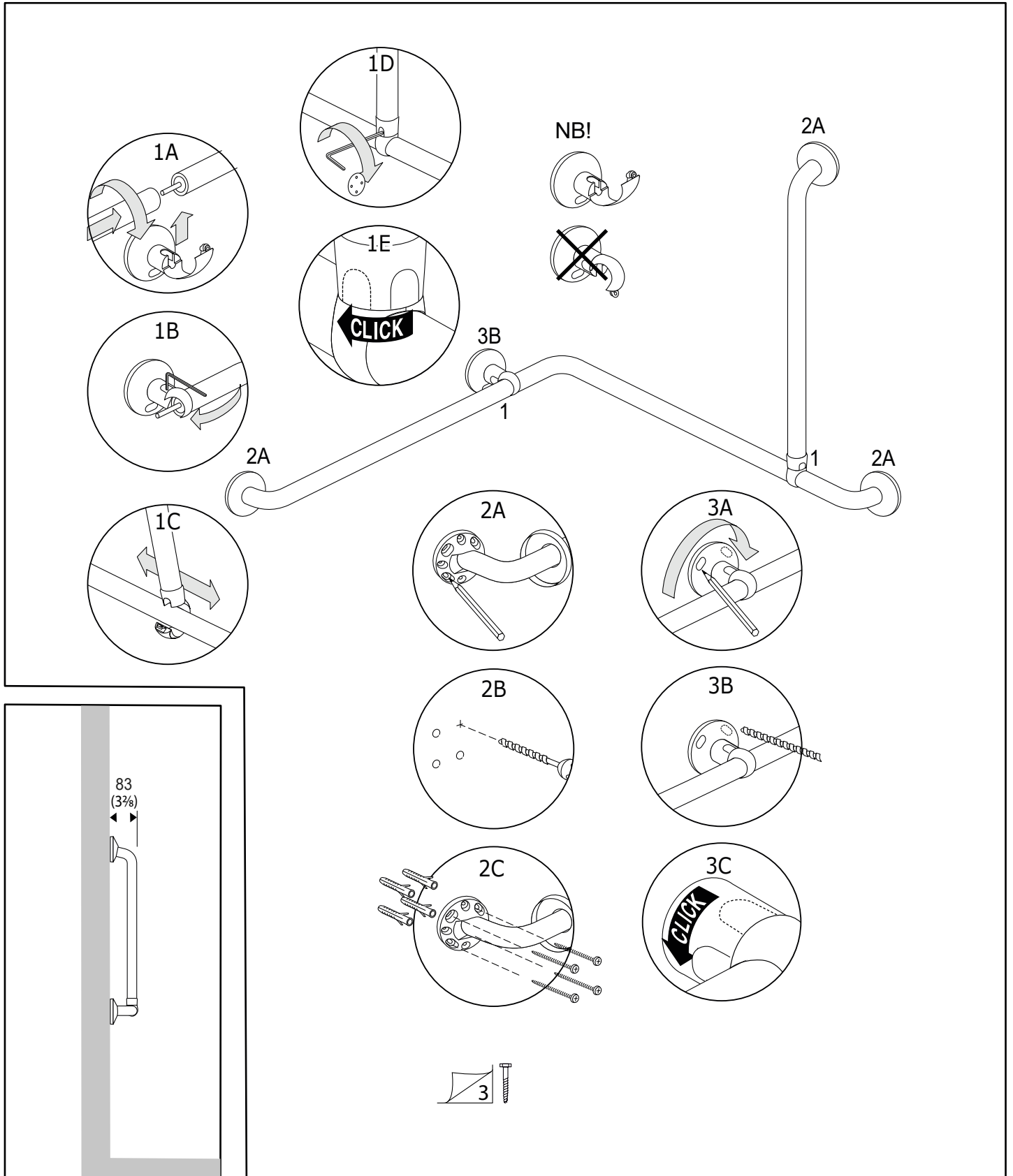

RT136

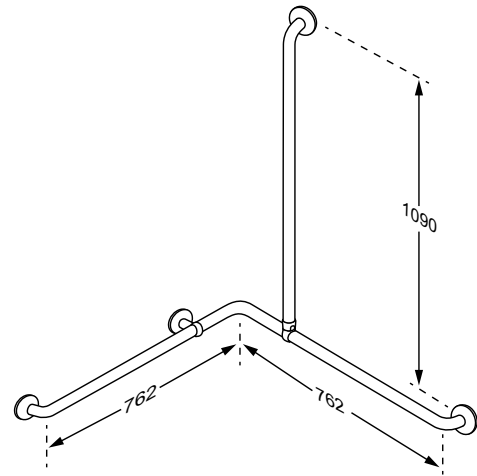
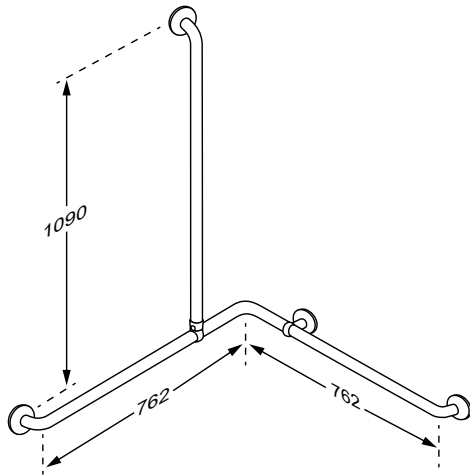

RT138

