



Independent 4 Life

McAlpine TSG2T 75mm Water Seal, 110mm Vertical Outlet, 150mm Sq. Security Tile / Grating

Product Code: TSG2T6SS

Product Images

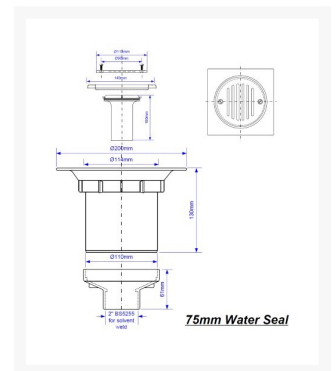

Description

The vertical outlet McAlpine TSG2T 75mm Water Seal Trapped Gully with a stainless steel square grate for tiled floor installations.

- 75mm water seal trapped gully for tiled wet rooms

www.independent4life.co.uk | info@independent4life.co.uk | Tel: 0800 500 3001 | VAT No: 942447711

EORI GB942447711000

- Two-piece gully designed for use with timber floors and floor formers and can be plumbed prior to installation of the floor or former
- Top access gully has a removable inner cup for easy cleaning
- Flow rates of 40 litres per minute exceed the minimum requirement of EN 1253-2:2003 and are variable dependent on the cover plate used
- 200mm overall diameter
- 110mm Vertical Outlet
- Supplied with 110mm x 2" BS EN 1329-1:2000 solvent spigot outlet
- Manufactured in ABS to the highest quality
- 150 x 150mm stainless steel square with circular grate (with screws) for tiled and stone floors
- Simple to install

Additional Information

Manufacturer	McAlpine
Configuration	Gravity Waste
Compatible Tray or Former	AKW - Tuff Form, AKW - Tuff Form8, AKW / Contour - ShowerDec, Maxxus
Installation	Floor Formers, Concrete / Screed Floors, Timber Floors
Application	Floor Former, Screed Floors, Timber Floors, Has Lockable Grate
Waste Diameter (mm)	200
Waste Outlet / Depth (mm)	Vertical
Flow Rate / l/min	40
Floor Finish	Tiled Flooring
Grate Material / Finish	Stainless Steel / Slotted