



Independent 4 Life

Granberg Verti 831 Height ADJ Wall Cabinet Lift, 400-1000 W x 315-400mm Int. Depth, Control OPT

£2,203.20 Inc. VAT

Product Code: 831-xxx

Product Images



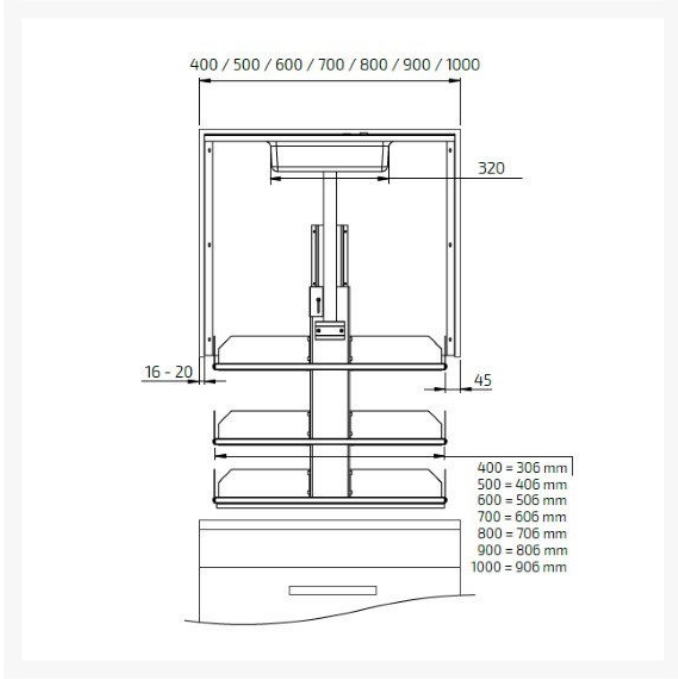
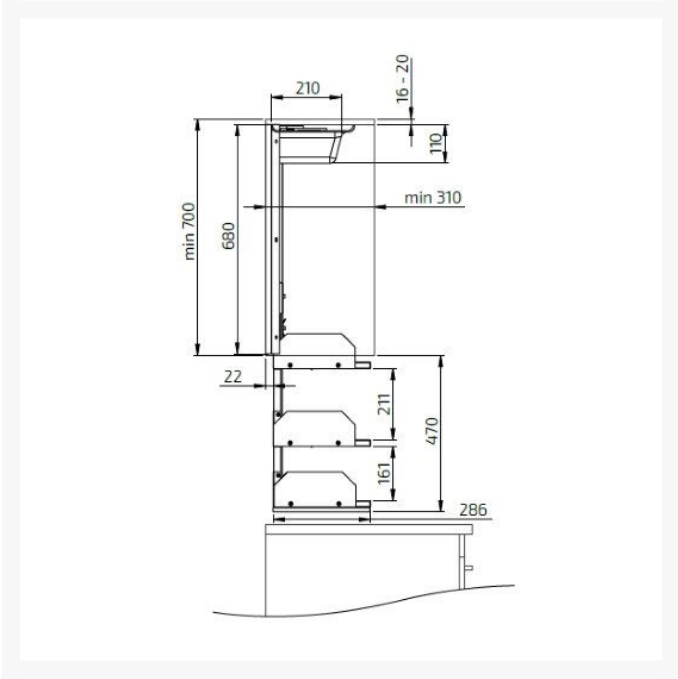



Product Options

Cabinet Width (mm)	Price Inc. VAT
400	£2,203.20
500	£2,245.32
600	£2,259.36
700	£2,314.44
800	£2,339.28
900	£2,371.68
1000	£2,411.64

Additional Options

Standard Wired Controls	Alu-design Control Buttons	£0.00
	Mini Control Buttons	£0.00
Upgrade to Wireless Controls	Radio Control Mini Buttons	£177.30
	Fixed Radio Control Button, Alu-design	£177.30
	Radio Control Button, Alu-design with Extension Frame	£219.60
	Radio Remote Hand Control - Single Channel	£213.30
Add Optional Lighting	2x LED Spotlights with Flexible Cable - Pre-fitted	£302.40

Description

The Granberg Verti 831 is a height adjustable wall cabinet lift for the kitchen.

Fitted inside the cabinet, the lift lowers the cabinet shelves and contents by 470mm in a vertical motion to the worktop below.

This version of the Verti is suitable for cabinets with an 315-400mm internal depth and comes with a choice of controls and optional factory fitted LED spotlights.

Key benefits:

- Electric height adjustable wall cabinet lift
- Lowers the cabinet's shelves and contents in a vertical motion to the worktop below

- Time for a lift or lowering stroke, approx. 10 seconds
- Quiet motors and discreet styling
- Integrated safety feature prevents the movement of the lift in the event of an obstruction

Choice of controls:

- Recessed - Corded Control Button in Alu-design, with 5m Control Cable (Product Code: 61310)
- Recessed - Corded Mini Control Buttons, backlit LED, with 5m Control Cable (Product Code: 61315)
- Recessed - Wireless Mini Control Buttons, backlit LED (Product Code: 61376)
- Recessed - Wireless Control Button in Alu-design (Product Code: 61371)
- Surface mounting - Wireless Control Button in Alu-design with Extension Frame (Product Code: 61371 + 61355)
- Single Channel Remote Control (Product Code: 61385)
- Multi-channel remote controls are also available if you are installing multiple systems

Integrated safety system:

- Each lift is supplied fitted with a safety stop panel located below the bottom shelf
- Micro-switches in the safety panel stops the lifts decent when contact is made. I.e. A glass on the worksurface
- Micro-switches located in the head of the unit prevent the upward motion if the event of an obstruction on the top shelf

Optional lighting:

- Factory fitted LED spot lights x 2, located below the safety stop plate
- LED strip lights are also available, with matching LED lights for fixed height cabinets - available separately (Product Codes: 61932 and 61931)

Wall cabinet requirements:

- Internal widths (mm): 360, 460, 560, 660, 760, 860 and 960
- Overall height (mm): 700 - 1100
- Wall cabinets over 700mm in height will require an internal fixed shelf above the lift
- Internal depth (mm): 315 - 400
- Side thickness (mm): 16 - 20

Technical details:

- Width of shelves (mm): 306, 406, 506, 606, 706, 806 and 906
- Depth of shelves (mm): 286mm
- Unit height: (mm): 680
- Vertical stroke, max. 470mm
- Speed level: 47mm / sec.
- Bottom safety stop: White finished MDF panel with micro-switches located beneath lowest shelf. When the panel is touched the lift stops
- Top safety stop: Light grey plastic cover with micro-switches. When the cover is touched the lift stops
- Electrical connection: Mains plug for 230 V, max 0.5A
- Power consumption: 105 W
- IP-class: IP 30
- Note: The Wireless and Remote-Control options require an additional plug socket for the remote receiver
- The plug sockets for the Verti should be located 50mm above the wall unit
- Control and lighting voltage: 24 V DC
- Weight including shelves, max. size: 28kg
- Max. Load in a cabinet / Lifting force: 40kg

- Noise pressure: Less than 70 dB(A)

Materials:

- Rear panel (thickness 16mm) and shelves (thickness 19mm) in white melamine
- Safety trip panel in white-painted MDF
- Powder coated sheet-metal parts (Alu-grey RAL 9006)
- Motor casing in Alu-grey plastic
- Aluminium sliding rail

Warranty:

- 2 year manufacturer warranty

Manufacturer product codes:

- 831-040-01, 831-040-06, 831-040-07, 831-040-08, 831-050-01, 831-050-06, 831-050-07, 831-050-08, 831-060-01, 831-060-06, 831-060-07, 831-060-08, 831-070-01, 831-070-06, 831-070-07, 831-070-08, 831-080-01, 831-080-06, 831-080-07, 831-080-08, 831-090-01, 831-090-06, 831-090-07, 831-090-08, 831-100-01, 831-100-06, 831-100-07, 831-100-08

Please note:

- For the installation of the Verti 831 lifting system, you must remove the base panel of your wall cabinet. 2x internal metal corner plates are included to strengthen the cabinet.
- Please note, the Verti-830 / 831 is not compatible with an “In-frame” wall cabinet. There is a pinch / entrapment risk with the front frame.

Additional Information

Manufacturer	Granberg
Model	Verti 831
Style	Cabinet Shelves Lower to User
Max. Distance Lowered (mm)	470
For Cabinet Width (mm)	400, 500, 600, 700, 800, 900, 1000
For Cabinet Height (mm)	700, 800, 900, 1000, 1100
For Cabinet Depth (mm)	315 - 400 (Internal)
Max. Load (kg / St)	40 / 6.3