



Independent 4 Life

Granberg Cover Panel for Centerlift 6490H

£396.72 Inc. VAT

Product Code: 6263-240-01

Product Images

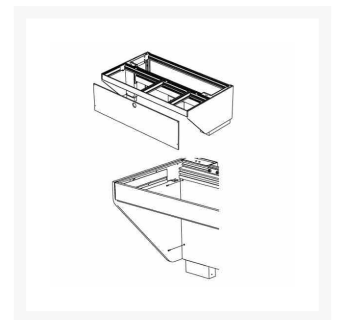
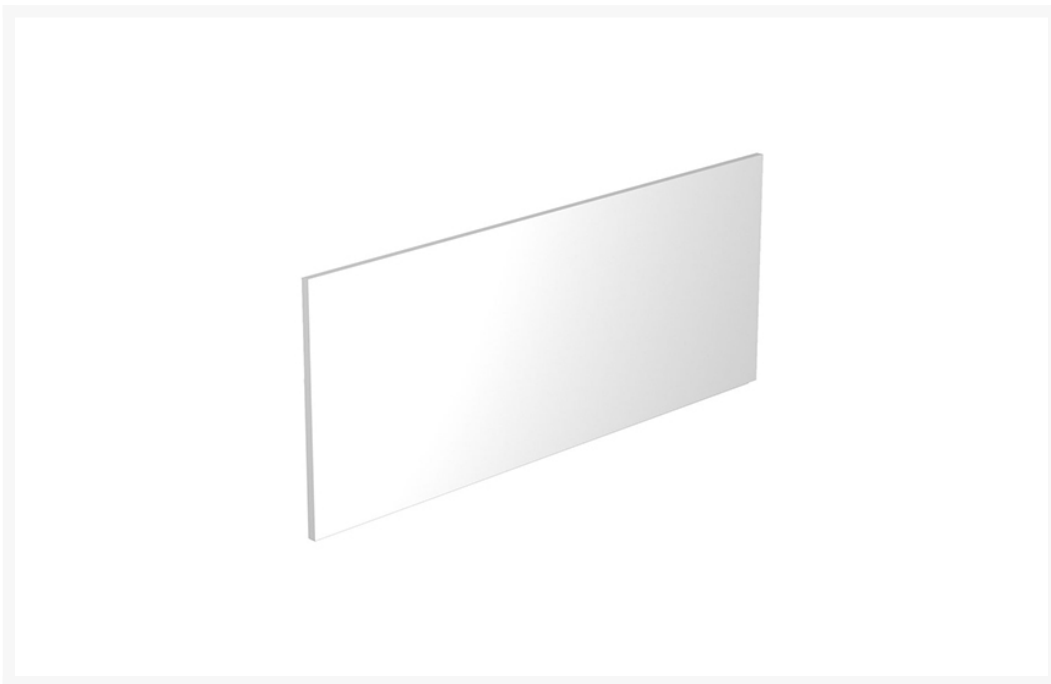

Description

Granberg cover panel, used to cover installations under the worktop on the Centerlift 6490H island lifting system.

Key benefits:

- Covers installations under the worktop
- Compatible with the Granberg Centerlift 6490H
- 12mm thick white melamine

- 510mm high

Fitting kit:

- Requires fitting kit (Product Code: 6263-001) for the Centerlift 6490H
- **See the PDF Downloads for more information**

Please note:

- For lifts over 2490mm, you will require 2x cover panels and 2x fitting kits

Warranty:

- 2 year manufacturer warranty

Additional Information

Manufacturer	Granberg
Compatible Model	Centerlift 6490HA