



Independent 4 Life

Pressalit PLUS Folding Seat, Fixed Height - Anthracite Grey

£440.10 Inc. VAT

Product Code: R5510112

Product Images

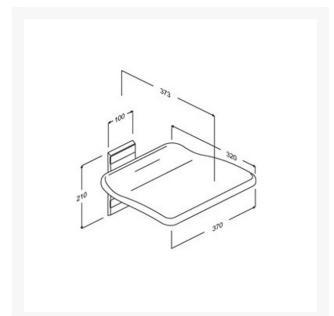
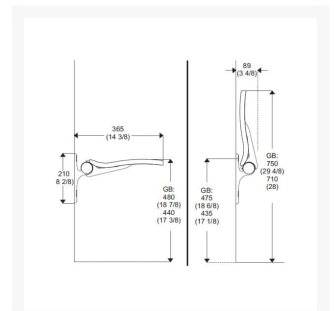
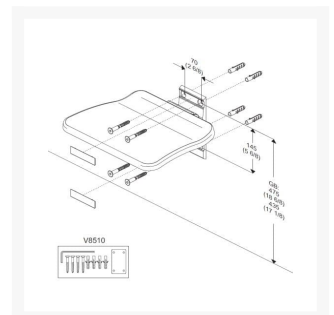

Description

Pressalit PLUS fixed height folding seat, an ergonomically shaped seat, which offers good and comfortable support.

Ideal when extra seating is required, but space is limited.

The seat is suitable for dry situations where additional seating is required and space is limited, such as in kitchens, lifts and corridors or on the landing.

Key benefits:

- Fixed height seat which folds away when not in use
- Stays up by itself, when folded away
- Excellent space saver
- Anthracite grey colour
- Includes wall fixing kit for brick walls

Technical details:

- Fixed height
- Seat contact surface area depth x width (mm): 320 x 370
- Projection from the wall (mm): 365
- Folded projection from the wall (mm): 89
- Maximum user mass (kg): 435
- Product weight (kg): 4.1

Materials:

- Folding seat: Thermoset plastic
- Mounting and suspension bracket: 10-micrometre anodized aluminium
- Ends caps: ABS polymer plastic

Warranty:

- 5 year manufacturer warranty

Please note:

- This seat is not recommended for use in **Wet areas, such as the shower**

Additional Information

Manufacturer	Pressalit
Mounting	Wall
Height Adjustment (mm)	None - Fixed Height
Operation	Manual Folding
Configuration	Seat Only
Seat Width (mm)	< 400
Height Adjustment (mm)	0 (Fixed)