



Independent 4 Life

£723.60 Inc. VAT

EASA Elegance LH Wide Full Height Fixed Panels - Custom Size (A) Min. 800, Max. 1200mm

Product Code: L1L-WIDE

Product Images

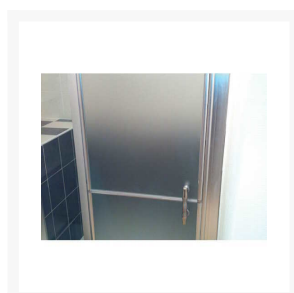
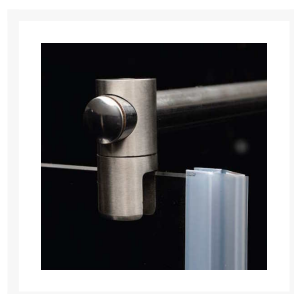
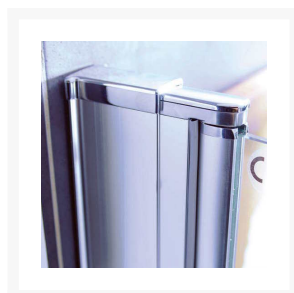
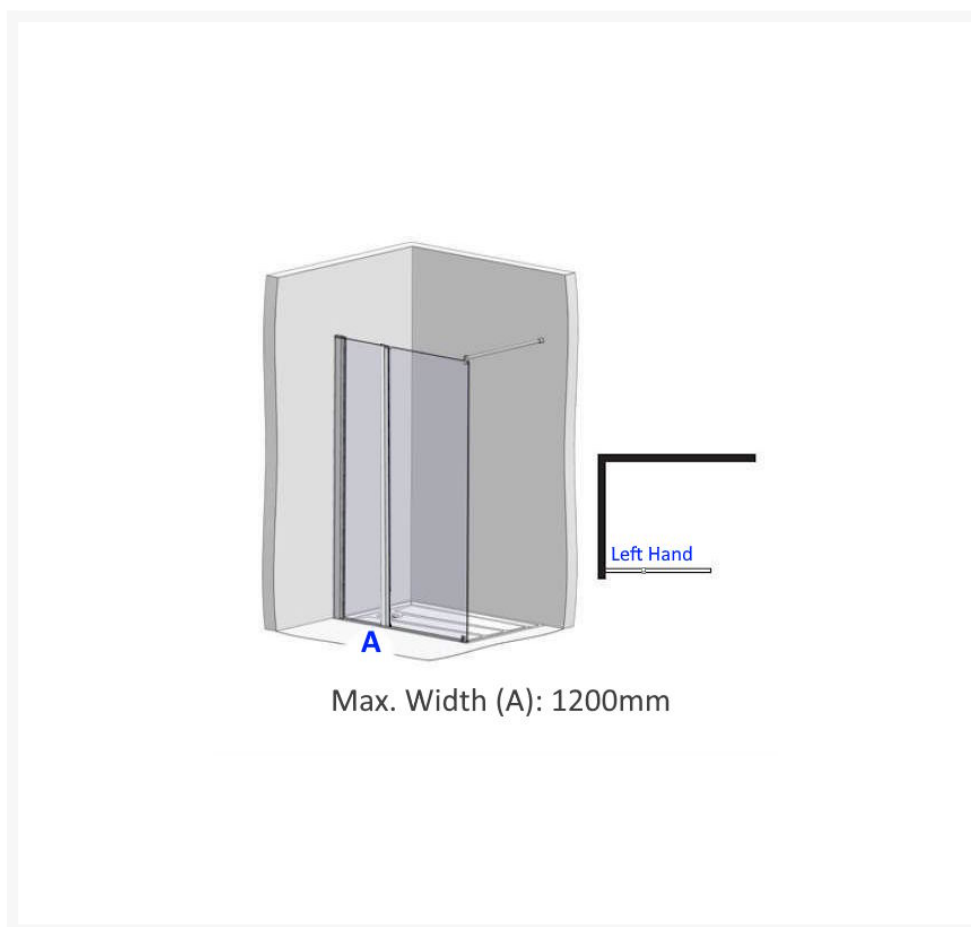

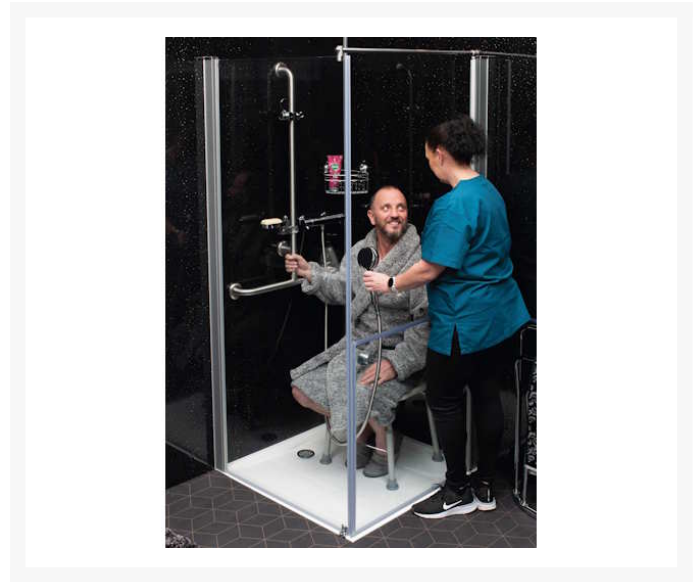
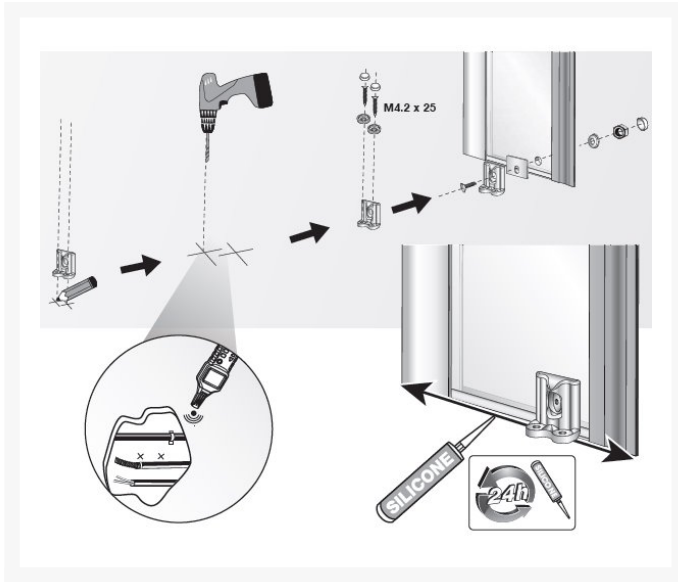

Additional Options

| | | |
|--|-----------------------------------|--------|
| Overall width of (A) both right hand fixed panels (min. 800, max. 1200mm) | | £0.00 |
| Width of your first left fixed panel (400-1000mm max.) | | £0.00 |
| Wall Profile | Square - Shower Trays/Floor Tiles | £0.00 |
| Installation type | Inline (Alcove) | £0.00 |
| | Corner | £0.00 |
| Optional - Upgrade to Privacy Glazing | Frosted Glass | £40.00 |

Description

This is the wide version of the L1L with two EASA 1900mm full-height fixed glass panels for a shower tray. Left-handed, manufactured to your dimensions between a range of 800 and 1200mm. Please state the width of each panel to equal your total required width to a maximum of 1200mm. Note: there will be a visible vertical glazing seal/bar between the two panels.

This shower screen panel offers the opportunity to install a wide glass screen where space is limited for the transportation and installation compared to a traditional full width screen.

The panels are well designed with 6mm thermally toughened safety glass, which is three times stronger than non-tempered glass.

Manufactured from high-quality materials that are easy to clean and maintain with anti-limescale glass.

EASA specialise in the design and manufacture of shower enclosures to suit those with disabilities, reduced

mobility and multi-generational living.

Key benefits:

- Anti-limescale glass for easier cleaning
- Adjustable wall profile, with a range of +15mm and -24mm
- Customisable total width (mm): 800–1200
- 100% recyclable

Components:

- 2x fixed left-hand custom width glass panels
- 1x stainless-steel 1000mm fixed panel lateral support bar (can be cut to length)
- 1x fixed panel mount, works in conjunction with the water seal at the base of the panel
- 1x stainless-steel wall compensator
- A satin finish bracket secures the fixed panel to a shower tray
- 6mm toughened/safety glass
- Seals and gaskets reduce the risk of water leakage and ensure a watertight seal

Technical details:

- Fixed glass panel heights (mm): 1900
- Wall compensator height (mm): 1920
- Wall compensator depth (mm): 55
- Wall compensator adjustment for off plumb walls of +15 to -24mm
- Customisable total width (min. to max. mm): 800 to 1200
- Please contact us if you require a custom height
- Optional — Frosted toughened safety glass for increased privacy

Compatibility:

- Can be retro-fitted onto a shower tray with a 40mm flat perimeter
- Wall compensator for shower trays

Accreditations:

- EU Construction Products Regulation (EU) No 305/2011 (CPR)
- BS EN 14428: 2015 + A1: 2018 Shower Enclosures/Doors
- BS EN 12150-1: 2015 + A1: 2019 Glass in building. Thermally toughened soda lime silicate safety glass
- BS EN 12600: 2002 Glass in building. Pendulum test. Impact test method and classification for their flat glass

Warranties:

- Accessories have a two-year warranty
- Lifetime warranty against manufacturing and material defects, excluding normal wear and tear in general domestic applications

Please note:

- These fixed panels are custom made and **non-returnable**
- These panels are supplied as two fixed panels and have a visible connecting strip between
- The minimum width each "panel" can be manufactured to is **400** and the maximum overall width of two panels is **1200mm**
- The free width of the "flat perimeter" of your shower tray

Additional Information

| | |
|------------------------------|--------------------------------------|
| Manufacturer | Easa Group |
| Height (mm) | 1900 |
| Shape | Full HT Fixed Panel (Left) |
| Tray Size (mm) | Custom Shower Tray Size |
| Handing | Left Hand |
| Fixed Front Panel Width (mm) | Custom Size 800 to 1200 |
| Door Entry Width (mm) | Custom Width |
| For Installation On | Shower Trays Only |
| Glass Thickness (mm) | 6 |
| Glazing | Clear - Toughened Safety Glass (TSG) |
| Finish | Chrome / Stainless Steel |