



Independent 4 Life

Pressalit PLUS Wash Basin Bracket, Lever Control, Electrically Height ADJ

£2,405.40 Inc. VAT

Product Code: R4750

Product Images

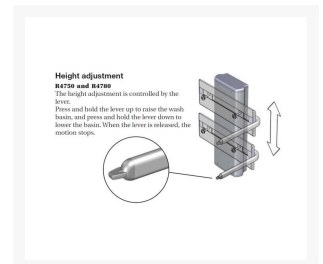
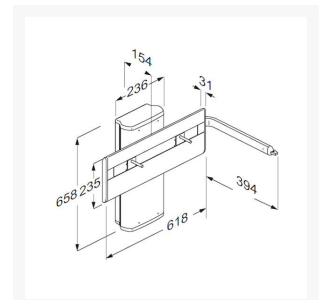

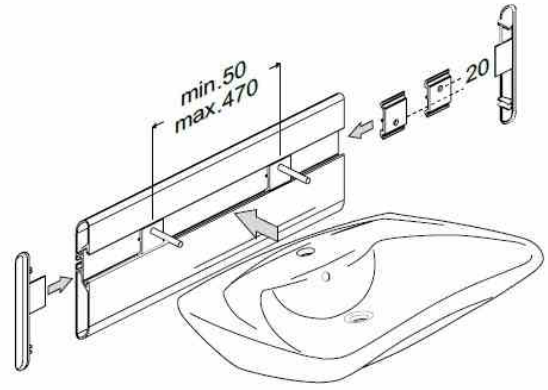
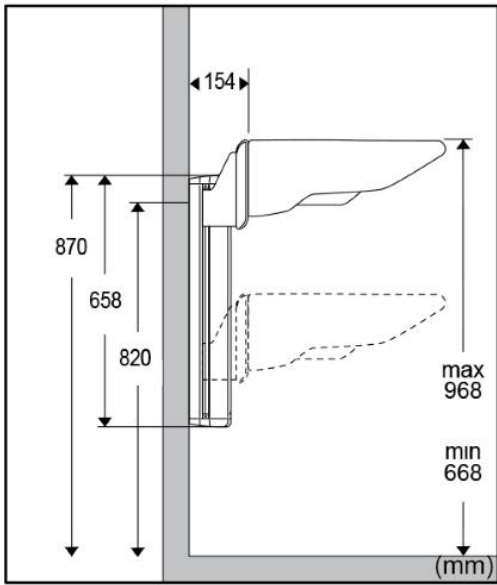

Bolt distance: Min. 50 – max. 470 mm.

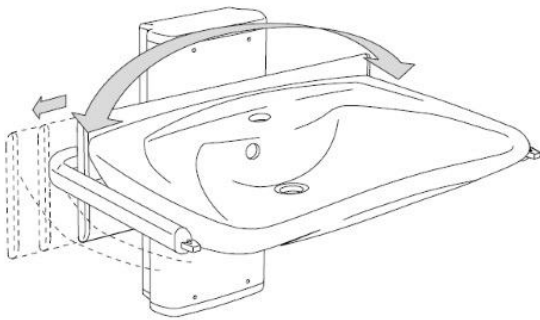

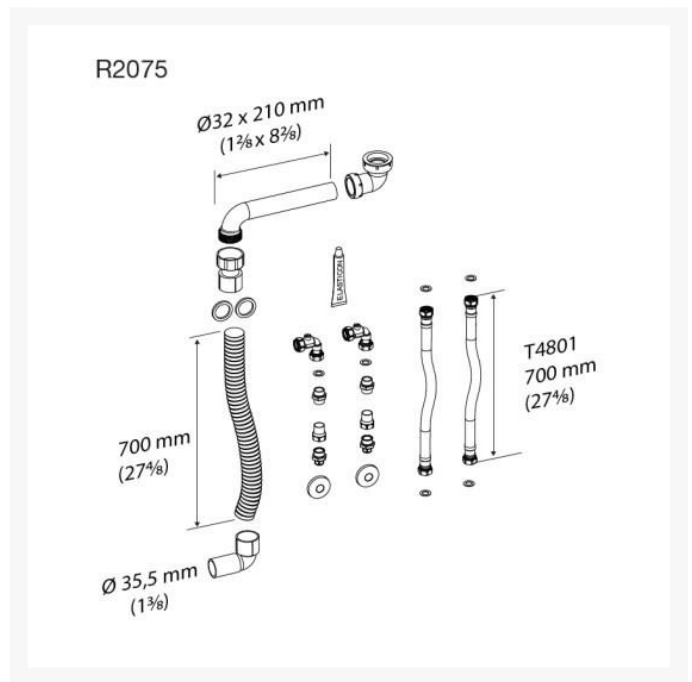
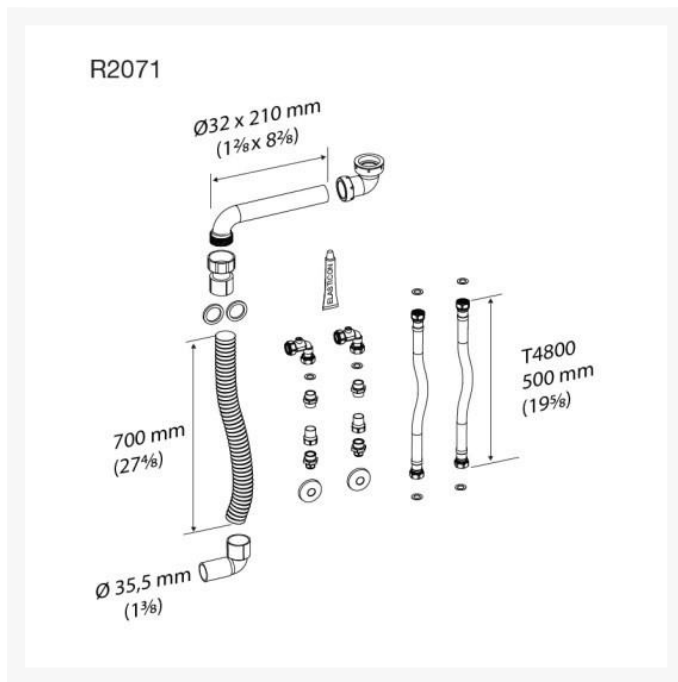

Additional Options

Product Code / Optional Pressalit feed and waste kit	R2071 / 500mm Flexible Feeds & 700mm Flexible Waste System	£219.95
	R2075 / 700mm Flexible Feeds & 700mm Flexible Waste System	£219.95

Description

Pressalit PLUS electrically operated height adjustable wash basin bracket with lever control, for mounting the Pressalit Matrix Curve, Matrix Curve II and Matrix Small wash basins.

The height of the wash basin can easily be adjusted by means of the lever control, ideal for regular adjustments without assistance.

For indoor use in a wet environment, such as a bathroom or wash room. The basin lift is intended to be used at room temperature, in a stand-alone environment, in private homes, nursing homes and hospitals under normal working conditions.

With the bracket mounted at the recommended height, the washbasin can be adjusted by 300mm from 668mm to 968mm above floor level.

Key benefits:

- 300mm Stepless electrical adjustment
- Suitable for use by all - adults, children, young and old
- Adapts to progressive needs of individuals
- Electrically operated with lever control - allows user to adjust the height of the basin themselves

- The height of the wash basin is easily adjusted by means of the lever control
- The lever control is placed by the front of the wash basin
- The lever control can be placed on the left or right-hand side of the wash basin
- Suitable for regular height adjustments - ideal for multi-user environments
- The arm that holds the lever control can also function as a towel rail
- The wash basin bracket suits all types of bolt-mounted wash basins
- Rounded, sleek design greatly facilitates cleaning
- Eliminates need for adaptation work in the future
- Includes fixing kit for basin (excludes wall fixing kit)

Technical details:

- Height adjustment range (mm): 300
- Width of basin mounting bracket (mm): 618
- Width of wall track (mm): 236
- Height of bracket (mm): 658
- Total projection from the wall (excluding basin) (mm): 154
- Length of lever control arm (mm): 394
- Weight (kg): 16.36
- For washbasins weighing (kg): 16-22
- Max load (including washbasin) (kg): 100
- Weight (kg): 16.36
- Speed, up (mm/s): 20
- Speed, downwards (mm/s): 23
- Noise level (dB): 45

Electrical technical details:

- Please refer to the PDF download for the installation instructions
- Duty cycle: The motor can be used for a maximum of 2 minutes of continuous operation, followed by 18 minutes pause
- Mains connection (V): 230
- Mains cable length to Transformer (mm): 3000
- Transformer to Actuator (V): 24
- Cable length from Transformer to Actuator (mm): 9500
- Current (A): 1.6
- Hz: 50-60
- Electrical rating (IP): IPX6 (Water projected in powerful jets, from a nozzle size up to 12.5mm - against the product from any direction shall have no harmful effects)
- Power consumption (max. load) (W): 75
- Power consumption (standby) (W): 1.5
- Actuator: LA40 (Linak) 4000N, IPX6
- Control box: SMPS14002
- Note: Upon installation the 2 pin plug must be removed and hard wired to a fused spur, as per electrical regulations

Materials:

- Washbasin bracket: Primarily made of 10-micrometre anodized aluminium
- Bracket ends: Capped with ABS polymer
- Lever control: ABS polymer switch at the end of an anodized aluminium arm

Declaration of conformity:

- CE UK MDR-MASK-RoHS This product is in compliance with all relevant requirements of:

www.independent4life.co.uk | info@independent4life.co.uk | Tel: 0800 500 3001 | VAT No: 942447711

EORI GB942447711000

- - Regulation (EU) 2017/745 on medical devices
- - Council Directive 2006/42/EC on machinery
- - Council Directive 2011/65/EC on RoHS. For the UK:
- - Medical Device Regulation (MDR) 2002 on medical devices
- - Supply of Machinery (Safety) Regulations 2008
- - Restriction of the Use of Certain Hazardous Substances in Electrical and Electronic Equipment Regulations 2012

Optional Pressalit WRAS approved waste kits:

- 500mm Flexible Feeds and 700mm Flexible Waste System (Product Code: R2071)
- 700mm Flexible Feeds and 700mm Flexible Waste System (Product Code: R2075)

Warranty:

- 5 year manufacturer warranty
- Salt and chloride have a corrosive effect on the products components and will cause a decrease in the life expectancy of the product
- The damaging effects can, however, be reduced if the product is showered with tap water on a daily basis

Former manufacturer code:

- The Pressalit PLUS range has superseded several former Pressalit Care products
- This item has replaced: R4260
- Please check for any changes to the product specification

Additional Information

Manufacturer	Pressalit
Bracket Range	Pressalit PLUS
Bracket Operation	Electric
Bracket Adjustment	Electric Lever
Height Adjustment (mm)	300
For Wash Basin Range	MATRIX Curve, MATRIX Curve II, MATRIX Small
Bracket Mounting	Wall
Safety Stop	No