



Independent 4 Life

Pressalit PLUS Basin Bracket, Wired Hand CONT, Electrically Height & Sideways ADJ

£2,602.80 Inc. VAT

Product Code: R4781

Product Images

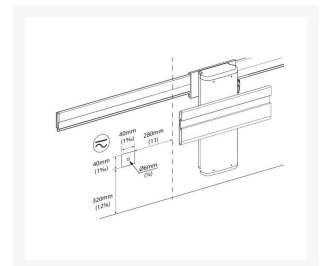
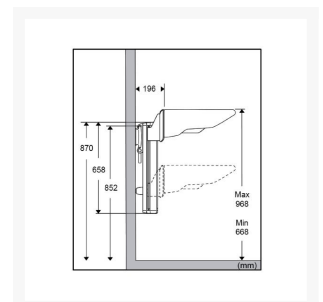
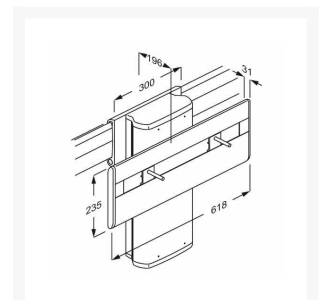

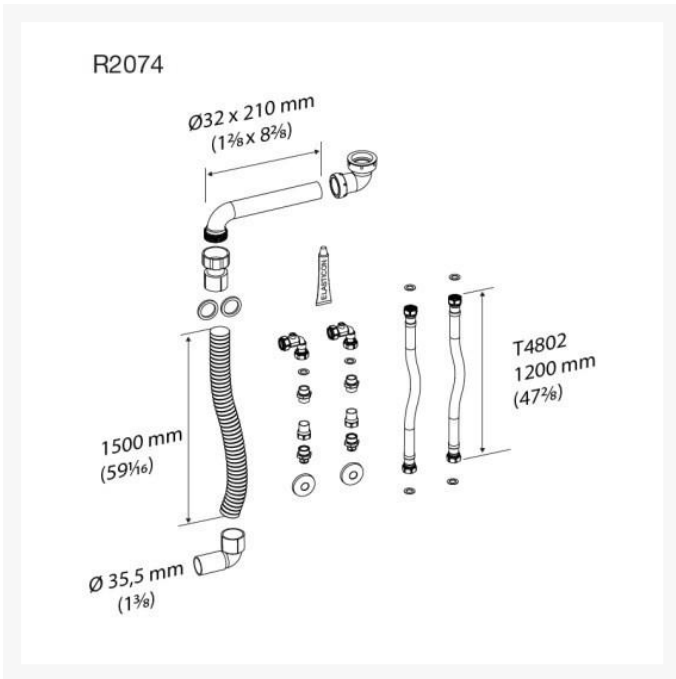
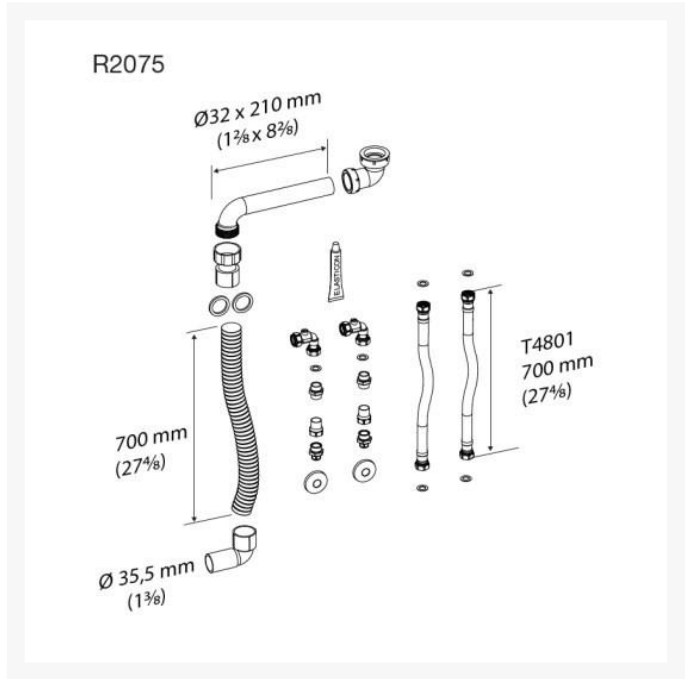

Additional Options

Product Code / Optional Pressalit feed and waste kit	R2075 / 700mm Flexible Feeds & 700mm Flexible Waste System	£219.95
	R2074 / 1200mm Flexible Feeds & 1500mm Flexible Waste System	£252.25

Description

Pressalit PLUS electrically operated, height adjustable washbasin bracket with horizontal manual movement. For mounting the Pressalit Matrix Curve, Matrix Curve II and Matrix Small wash basins.

The bracket is electrically operated via a wired hand control, making it suitable for continuous height adjustments by the user of the washbasin without assistance.

Available separately, this product is designed to be mounted on a Pressalit PLUS horizontal wall track in range of lengths from 600 to 3900mm to facilitate sideways movement (Product Code: R98xx112) and Pressalit Track Stop End(s) (Product Code: RT761).

For indoor use in a wet environment, such as a bathroom or wash room. The basin lift is intended to be used at room temperature, in a stand-alone environment, in private homes, nursing homes and hospitals under normal working conditions.

With the bracket mounted at the recommended height, the washbasin can be adjusted by 300mm from 668mm to 968mm above floor level.

Key benefits:

- 300mm Stepless electrical adjustment
- For mounting on the Pressalit PLUS horizontal wall track (not included), for manual sideways movement
- Suitable for use by all - adults, children, young and old
- Adapts to progressive needs of individuals
- Maximum flexibility for multiple users/changeable conditions
- Electrically operated with wired hand control - allows user to adjust the height of the basin themselves
- Supplied with a hook for the wired hand control
- The wash basin bracket suits all types of bolt-mounted wash basins
- Rounded, sleek design greatly facilitates cleaning
- Eliminates need for adaptation work in the future
- Includes fixing kit for basin

Technical details:

- Height adjustment range (mm): 300
- Width of basin mounting bracket (mm): 618
- Width of wall track (mm): 236
- Height of bracket (mm): 658
- Total projection from the wall when mounted on the horizontal PLUS track (excluding basin) (mm): 196
- Weight (kg): 17.70
- For washbasins weighing (kg): 16-22
- Max load (including washbasin) (kg): 100
- Speed, up (mm/s): 20
- Speed, downwards (mm/s): 23
- Noise level (dB): 45

Electrical technical details:

- Please refer to the PDF download for the installation instructions
- Duty cycle: The motor can be used for a maximum of 2 minutes of continuous operation, followed by 18 minutes pause
- Mains connection (V): 230

- Mains cable length to Transformer (mm): 3000
- Transformer to Actuator (V): 24
- Cable length from Transformer to Actuator (mm): 9500
- Current (A): 1.6
- Hz: 50-60
- Electrical rating (IP): IPX6 (Water projected in powerful jets, from a nozzle size up to 12.5mm - against the product from any direction shall have no harmful effects)
- Power consumption (max. load) (W): 75
- Power consumption (standby) (W): 1.5
- Actuator: LA40 (Linak) 4000N, IPX6
- Control box: SMPS14002
- Wired remote control: HB3 (Linak) IPX6
- Note: Upon installation the 2 pin plug must be removed and hard wired to a fused spur, as per electrical regulations

Materials:

- Washbasin bracket: Primarily made of 10-micrometre anodized aluminium
- Bracket ends: Capped with ABS polymer
- Wired hand control: Encased in polypropylene

Declaration of conformity:

- CE UK MDR-MASK-RoHS This product is in compliance with all relevant requirements of:
- - Regulation (EU) 2017/745 on medical devices
- - Council Directive 2006/42/EC on machinery
- - Council Directive 2011/65/EC on RoHS. For the UK:
- - Medical Device Regulation (MDR) 2002 on medical devices
- - Supply of Machinery (Safety) Regulations 2008
- - Restriction of the Use of Certain Hazardous Substances in Electrical and Electronic Equipment Regulations 2012

Optional Pressalit WRAS approved waste kits:

- 700mm Flexible Feeds and 700mm Flexible Waste System (Product Code: R2075)
- 1200mm Flexible Feeds and 1500mm Flexible Waste System (Product Code: R2074)

Warranty:

- 5 year manufacturer warranty
- Salt and chloride have a corrosive effect on the products components and will cause a decrease in the life expectancy of the product
- The damaging effects can, however, be reduced if the product is showered with tap water on a daily basis

Former manufacturer code:

- The Pressalit PLUS range has superseded several former Pressalit products
- This item has replaced: R4670
- Please check for any changes to the product specification
- Please also note that items in the PLUS range cannot be mounted onto older Pressalit wall tracks, and vice versa

Additional Information

Manufacturer	Pressalit
Bracket Range	Pressalit PLUS
Bracket Operation	Electric
Bracket Adjustment	Wired Hand Control
Height Adjustment (mm)	300
For Wash Basin Range	MATRIX Curve, MATRIX Curve II, MATRIX Small
Bracket Mounting	Horizontal PLUS Track
Safety Stop	No