



Independent 4 Life

McAlpine S/S Horiz Gully 2" O/L 1 1/2" Reducer - Tiled Flooring

£94.72 Inc. VAT

Product Code: TSG52T150SSCON

Product Images

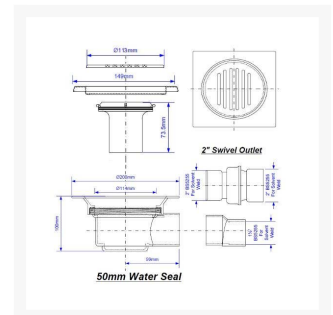
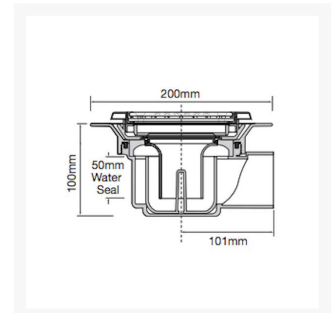

Description

The McAlpine TSG52 shower waste, upgraded with a stainless steel square grate for tiled and stone floor installations.

Key benefits:

- 50mm water seal trapped gully for tiled wet rooms

- Two-piece gully designed for use with screed or timber floors and floor formers and can be plumbed prior to installation of the floor or former
- Top access gully has a removable inner cup for easy cleaning
- Flow rate of 40 litres per minute exceed the minimum requirement of EN 1253-2:2003 and are variable dependent on the cover plate used
- 200mm overall diameter
- 100mm depth
- 2" BS EN 1329-1:2000 Solvent Weld Horizontal Outlet with 2" x 1 1/2" solvent weld socket reducer
- Manufactured in ABS to the highest quality
- 150 x 150mm stainless steel square with circular grate (without screws) for tiles with a depth of up to 8mm
- Simple to install

Alternative product code:

- Former Contour Showers (Product code: 08GT52-S)

Additional Information

Manufacturer	McAlpine
Configuration	Gravity Waste
Compatible Tray or Former	AKW - Tuff Form, AKW - Tuff Form8, AKW / Contour - ShowerDec, Maxxus
Installation	Floor Formers, Concrete / Screed Floors, Timber Floors
Application	Floor Former, Screed Floors, Timber Floors
Waste Diameter (mm)	200
Waste Outlet / Depth (mm)	Horizontal
Flow Rate / l/min	40
Floor Finish	Tiled Flooring
Grate Material / Finish	Stainless Steel / Slotted